

IAME

THE HEART OF KART



INSTALLATION MANUAL

"MINI SWIFT 60cc - USA"



INDEX

	PAGE
GENERAL DESCRIPTION OF THE ENGINE	
CHARACTERISTICS OF THE ENGINE – OPERATIONAL LIMITS	1
1- Contents of packing	2
2- Motor Identification Number	3
3- Preparation and installation of the engine on the chassis	4
3.1 Installation sketch of the engine on the chassis	4
3.2 Exhaust header assembly	5
3.3 Preparation and installation of the motor-mount	6
3.4 Install the carburetor	6
3.5 Install the engine on the chassis	7
3.6 Install the clutch cover with H.T. coil	8
3.7 Installation Electrical connections	9
3.8 Electrical connections on the engine	10
3.9 Install the intake silencer	14
3.10 Install the exhaust	14
4- Gasoline and Oil	15
5- Tillotson HW-31A carburettor adjustment	16
6- Starting and stopping the engine	17
7- Engine break-in	17
8- Inlet silencer	17
9- Recommendations on the exhaust system	17
10- Centrifugal clutch	18
11- Instructions for the disassembly /assembly of the clutch	19
12- Battery	21
13- Use of the battery charger	22
14- Spark-plug and thermal degree	23
15- Choice of the best sprocket ratio	24
16- Scheduled maintenance	26
17- Troubleshooting	27
18- Engine preservation	28
attachments: - Fastener Torque Table	28
- Wiring Diagram	29



GENERAL DESCRIPTION OF THE ENGINE

This engine of the TaG series (Touch and Go) has been expressly designed and developed for the powering of karts, either for hobby or racing, on closed tracks destined for this specific purpose. When designing this new line of engines, the technical solutions already adopted for the high performance engines were used, in order to guarantee the highest reliability and lasting of components, when the operating limits are respected.

The motor is a single cylinder using the two stroke principle.

The cylinder and the crankcase are in aluminium alloy.

The pressed-in liner is made of centrifugated cast iron, fully machined to guarantee the best possible stability and sliding homogeneity.

The head is separated from the cylinder and secured by studs.

The crankshaft is built and supported by ball-bearings. The crankshaft is of steel alloy, hardened and tempered, as is the connecting rod which runs on roller bearings.

The ignition includes a 2 pole stator/rotor, an H.T. coil, a starter relay and complete wiring harness.

The spark is generated also without a battery: it is therefore possible, in case of emergency, to start the engine with an external starter unit.

The engine has an integrated electric starter. By pushing the green start button, the starter activates a Bendix type gear which engages the starter ring assembled on the clutch.

The engine is provided with a dry centrifugal clutch with low maintenance and with interchangeable sprocket .

The carburettor type is a diaphragm (series Tillotson HW) includes an integrated fuel pump and filter, and is able to operate in any position.

The battery (12 V- 7.2Ah) is a sealed, no maintenance, battery is NOT supplied, the battery supports box be easily adapted to all existing chassis.

The exhaust, included in the supply, is already tuned for the best possible performance.

The engine is also equipped with a centrifugal dry clutch with low maintenance with incorporated sprocket.

The exhaust system, including in the supply, is already tuned and optimized to ensure the best possible performance.



ENGINE CHARACTERISTICS – OPERATIONAL LIMITS

The characteristics of the engine are the following :

- Cycle: OTTO / 2 stroke
- Original cubic capacity: 59.00 cc
- Original bore 41.80
- Max. theoretical bore: 42.10 mm
- Stroke : 43.00 mm
- Lubrication : fuel-oil mix 6%
- Induction: inlet in 3rd port (Piston Port)
- Carburetor: Diaphragm type, Tillotson HW-31A (Ø17mm)
- Cooling : Free air
- Ignition : Analogic / 2 poles, with internal rotor
- Electric starter: 12V / 0.15 Kw
- Clutch : Automatic, dry centrifugal

Operational limits:

- Max.RPM / 1' : 14.500 RPM



ATTENTION:

Never exceed the above limits, no obligation of IAME exists in case the above limits are exceeded.

1- CONTENTS OF PACKING

Each engine is supplied with the accessories under shown:

EXHAUST	Quantity
• Exhaust silencer spring	2
• Exhaust manifold	1
• Exhaust muffler	1
INDUCTION	
• Tillotson carburettor	1
• Intake silencer	1
• Intake silencer support	1
ELECTRIC PLANT	
• Battery support	1
• Battery fixing strap	1
• Battery fixing clamps	2
• Electrical harness	1
• Push buttons support bracket	1
• Starter relay	1
• NGK BR 9 EG spark plug	1
• Spark plug cap	1
• Fixing clamps	8
MISCELLANEOUS	
• Clutch cover with coil	1



ACCESSORIES

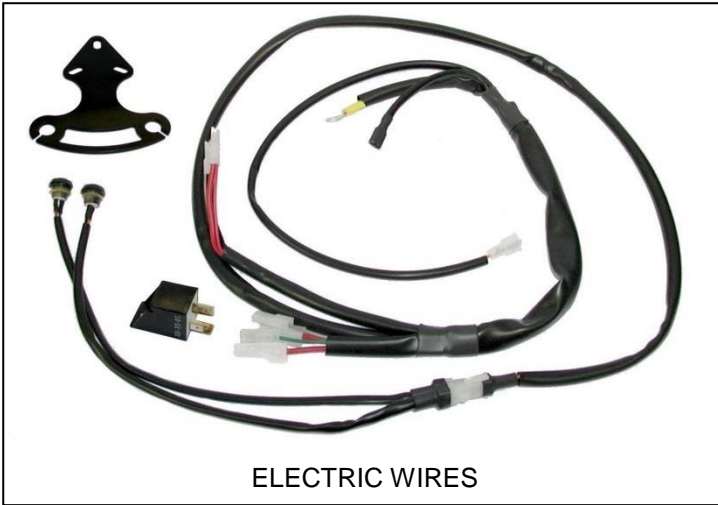

ELECTRIC WIRES



BATTERY SUPPORTS



EXHAUST GROUP

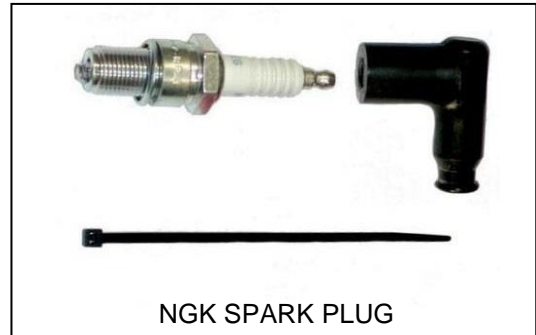

NGK SPARK PLUG



CLUTCH COVER



TILLOTSON HW-31A CARBURETTOR



INTAKE SILENCER



INTAKE GROUP



2- MOTOR IDENTIFICATION NUMBER

The official identification number can be found stamped on the lower left part of the crankcase, next to the electric starter (see fig.). The number normally includes a letter followed by 4 digits.

Other numbers stamped on the crankcase or other surfaces of the motor refer to various manufacturing processes and do not identify the engine.

NOTE:

In case of need for spare parts and when contacting the IAME Support Centers, please always refer to the Motor Identification Number and to the motor model.



3- PREPARATION AND INSTALLATION OF THE ENGINE ON THE CHASSIS

NOTE:

In case the engine is supplied already assembled on the chassis, it is at care of the assembler to follow these instructions. The final customer, in this case, can skip this section and can start reading from section 4.

Whenever the engine or a component is disassembled, it is necessary to always follow the under shown instructions for proper reassembly.

3.1- INSTALLATION SKETCH OF THE ENGINE ON THE CHASSIS

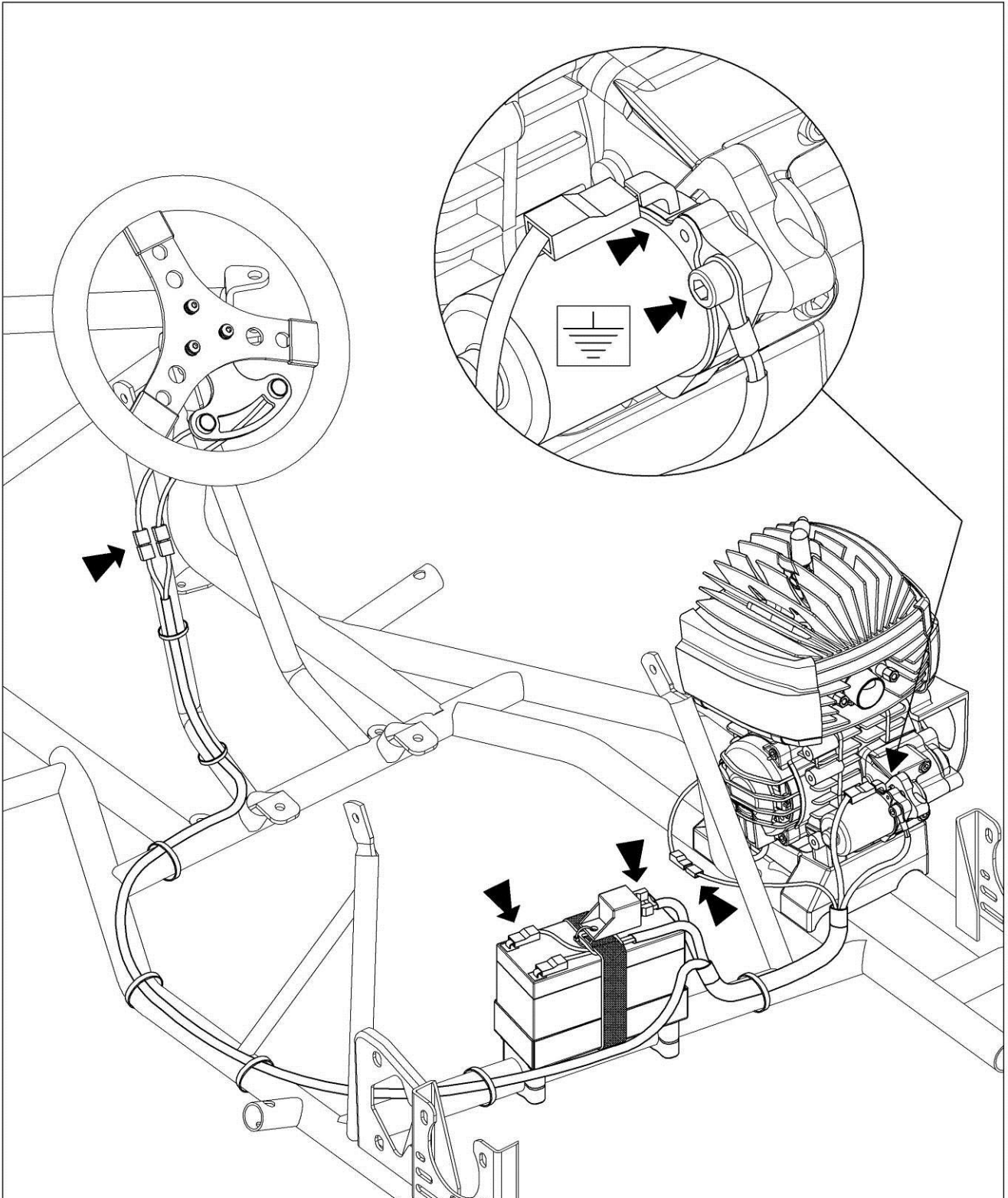

3.2 EXHAUST HEADER ASSEMBLY

NOTE:
THE ENGINE IS SUPPLIED WITH THE EXHAUST GASKET AND NUTS ALREADY INSERTED , WHEN THE SHIPMENT IS MADE AN EXHAUST COVER GASKET IS PROVIDED TO PROTECT THE INTERNAL PARTS.

3.2.1 REMOVE NUTS AND EXHAUST COVER.

3.2.2 INSTALL SPRINGS ON THE EXHAUST HEADER (SEE FIG 1).

MAKE SURE THAT THE EXHAUST GASKET IS IN SEAT AND INSTALL THE EXHAUST HEADER (SEE FIG 2).

NOTE:
ON THE "BABY" VERSION THE EXHAUST HEADER IS NOT REQUIRED.

3.2.3 INSTALL THE 2 WASHERS 6mm

SUGGESTION:
PUT THE ENGINE IN HORIZONTAL POSITION (USE A SCREWDRIVER IF NECESSARY) AND INSTALL THE WASHERS IN SEAT.

3.2.4 INSTALL THE 2 NUTS (SEE FIG 3).

TORQUE AT 9 ÷ 11 Nm (80 ÷ 100 in-lb)

"T" WRENCH 10 mm



3.3

PREPARATION AND INSTALLATION OF THE MOTOR-MOUNT

NOTE: ALL THE DIMENSIONS ARE IN MILLIMETERS

3.3.1 DRILL 4 HOLES (DIAM. 8.5mm) INTO THE MOTOR-MOUNT .

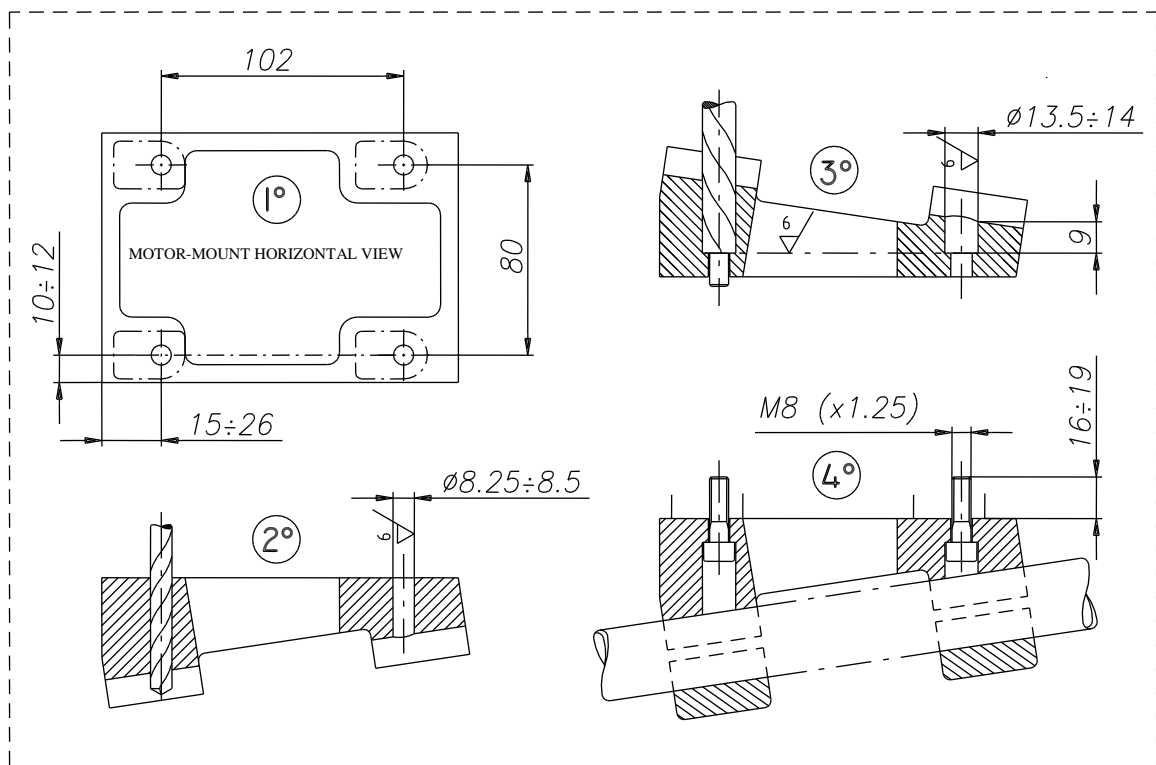

3.3.2 INSTALL THE MOTOR-MOUNT. MAKE SURE TO USE M8 ALLEN SCREWS WITH A LENGTH SUCH AS TO ENGAGE, IN THE CRANKCASE, A THREADED PORTION LENGTH OF 16±19mm (THE SCREW MUST PROTRUDE FROM THE PLATE, FOR 16±19mm) (SEE FIG. 4 AND DRAW.)

**4 ALLEN SCREWS M8
TORQUE AT 22÷24 Nm (190 ÷ 210 in-lb)**

(6mm ALLEN WRENCH)

Fig.4



3.4 INSTALL THE CARBURETTOR

- REMOVE THE PLASTIC CAP
- KEEPING 1 CARBURETTOR GASKET ON THE ENGINE, INSTALL: (SEE FIG.10)

- N.2 THERMAL SPACER (15mm+11.5mm)
- N.2 CARBURETTOR GASKET
- CARBURETTOR
- N.2 COLOMN NUTS

12 POINT WRENCH 5mm

-CONNECT BY APPROPRIATE PIPE; THE INTAKE PRESSURE MANIFOLD ON THE CARBURETTOR AND THE INTAKE PRESSURE MANIFOLD ON THE CRANKCASE.

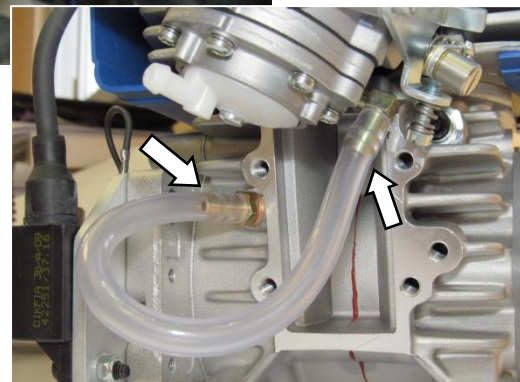

Fig.10



3.5

INSTALL THE ENGINE ON CHASSIS

3.5.1 PLACE THE ENGINE ON THE 2 OUTSIDE MAIN RAILS AND FIX THE MOTOR-MOUNT WITH THE TWO CLAMPS (SEE FIG.12).

SUGGESTION:
NEVER TORQUE COMPLETELY THE CLAMPS UNTIL THE CHAIN IS INSTALLED AND PROPERLY ALIGNED.



Fig.12

3.5.2 CHECK THE ALIGNMENT OF THE ENGINE SPROCKET AND THE AXLE SPROCKET (SEE FIG. 13).

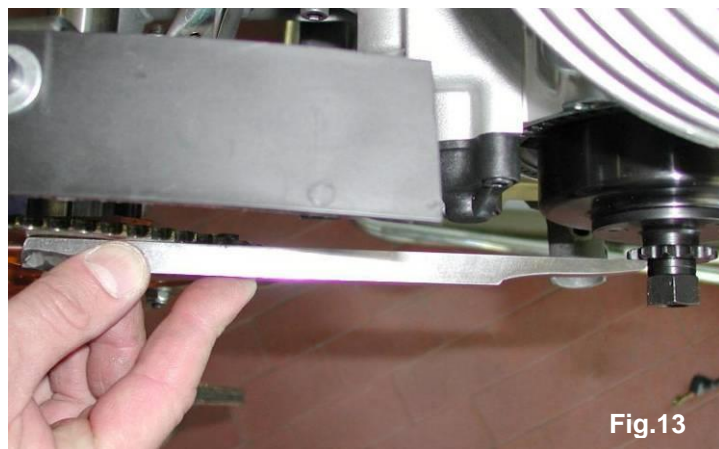



Fig.13

3.5.3 INSTALL THE CHAIN (PITCH: 7.775). (SEE FIG. 14).



Fig.14

3.5.4 MOVE THE ENGINE ON THE RAILS AND OPTIMIZE THE CHAIN TENSION.

 **ATTENTION:**
THE PLAY OF THE CHAIN MUST BE APPR. 15mm, MEASURED IN THE SHOWN POINT (SEE FIG. 15)

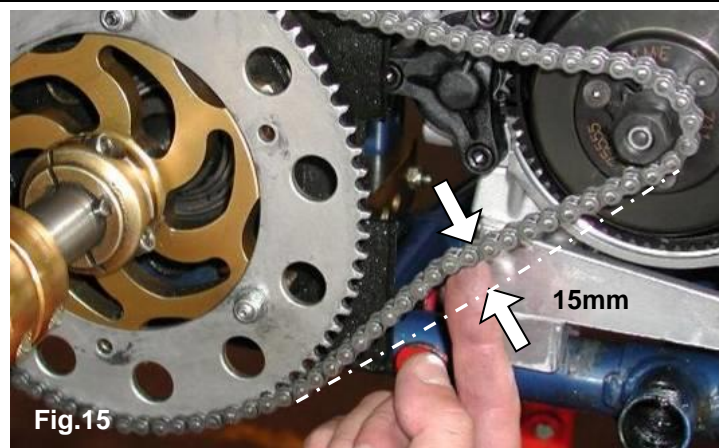

Fig.15

3.5.5 TORQUE THE CLAMPS SCREWS



3.6 INSTALL THE CLUTCH COVER WITH H.T. COIL

3.6.1 REMOVE THE 3 SCREWS M6x30 ON THE CRANKCASE (SEE FIG. 16-A) AND INSTALL THE CLUTCH COVER WITH H.T. COIL (SEE FIG.16-B)

TORQUE THE 3 SCREWS AT $8 \div 10$ Nm
(70 \div 90 In-lb)

(5 mm ALLEN WRENCH)



ATTENTION:
MAKE SURE THAT THE COPPER GROUND CABLE ALWAYS CONNECTS THE COIL WITH THE ENGINE. AN INADEQUATE GROUNDING COULD DAMAGE THE IGNITION BEYOND REPAIR.

THE POSITION OF THE H.T. COIL HAS BEEN CHOSEN TO BE AS FAR AS POSSIBLE FROM THE EXHAUST AS THE EXCESSIVE HEAT COULD DAMAGE THE COIL BEYOND REPAIR.

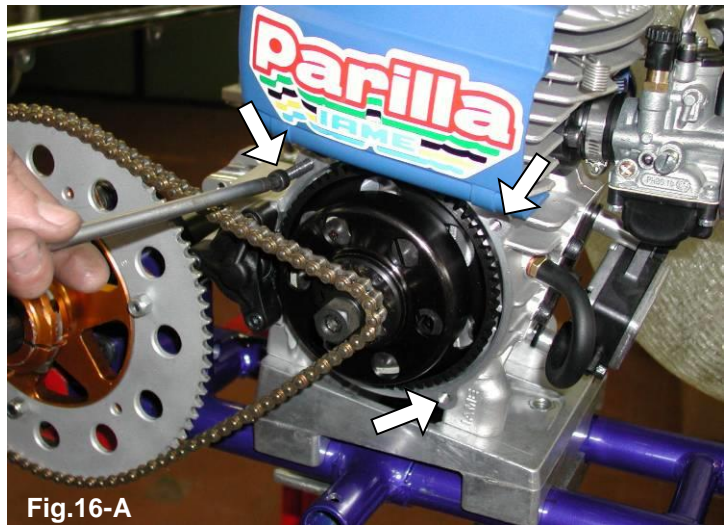

Fig.16-A

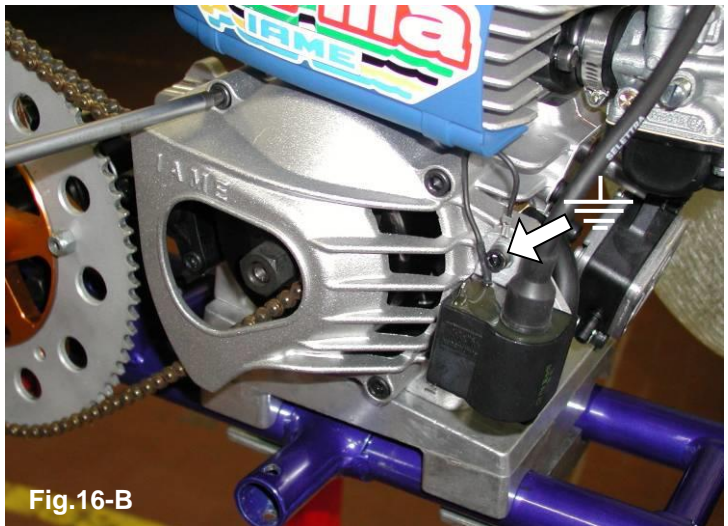

Fig.16-B



ELECTRICAL CONNECTIONS

(refer to the attached electrical schematic)

3.7

INSTALL THE CLAMPS ON THE BATTERY SUPPORT (SEE FIG.17).
N°2 SCREWS M6x10

TORQUE SCREWS AT 8÷10 Nm
(70 ÷ 90 in-lb)

(12 POINT WRENCH 10 mm)



Fig.17



3.7.1 POSITION THE SUPPORT ON THE CHASSIS REAR RAIL (SEE FIG.18).

Fig.18



3.7.2 FIX THE CLAMPS (SEE FIG.19).
N° 2 SCREWS M6x25

TORQUE SCREWS AT 8÷10 Nm
(70 ÷ 90 in-lb)

(5 mm ALLEN WRENCH)



Fig.19



3.7.3 INSERT THE STRAP INTO THE SUPPORT SLOTS

(SEE FIG.20).

Fig.20



3.7.4 POSITION THE BATTERY ON THE SUPPORT (SEE FIG.21).

SUGGESTION:
NEVER CONNECT THE BATTERY UNTIL YOU ARE READY TO START THE ENGINE.



ATTENTION:
PAY ATTENTION NOT TO SHORT CIRCUIT THE BATTERY TERMINALS AS BATTERY COULD BE DAMAGED BEYOND REPAIR.



Fig.21

3.7.5 CONNECT THE STARTER RELAY TO THE CABLE TERMINALS (SEE FIG.22).

NOTE:
THE 2 CABLES PROVIDED WITH 10mm TERMINALS CAN BE INVERTED ON THE STARTER RELAY, WITHOUT CAUSING ANY MALFUNCTION PROBLEMS.
ALSO THE 2 CABLES WITH 6.3mm TERMINALS CAN BE INVERTED.

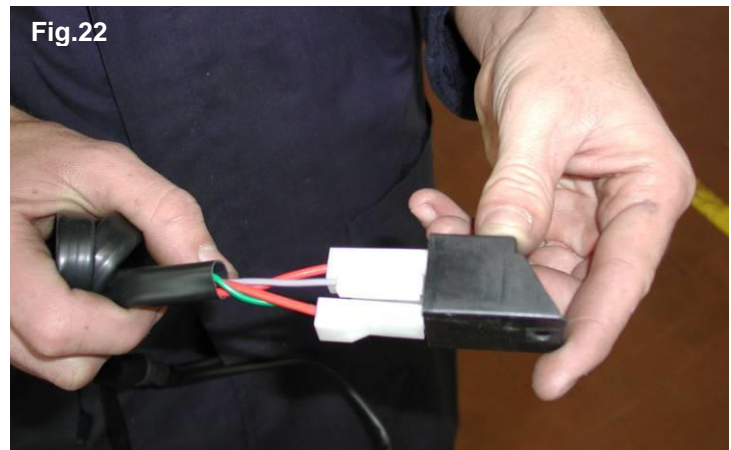

Fig.22

3.8 ELECTRICAL CONNECTIONS ON THE ENGINE (REFER TO THE ATTACHED ELECTRICAL SCHEMATIC)

UNSCREW THE M6 SCREW ON THE STARTER AND CONNECT THE GROUND CABLE TO THE ENGINE. (SEE FIG.23).

**TORQUE SCREW AT 8÷10 Nm
(70 ÷ 90 in-lb)**

(5 mm ALLEN WRENCH)

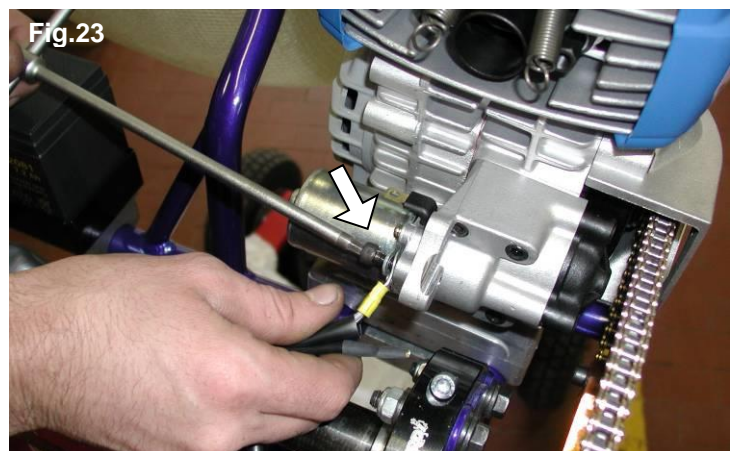

Fig.23

3.8.1 CONNECT THE TERMINAL (8mm) OF THE HARNESS TO THE STARTER (SEE FIG.24).

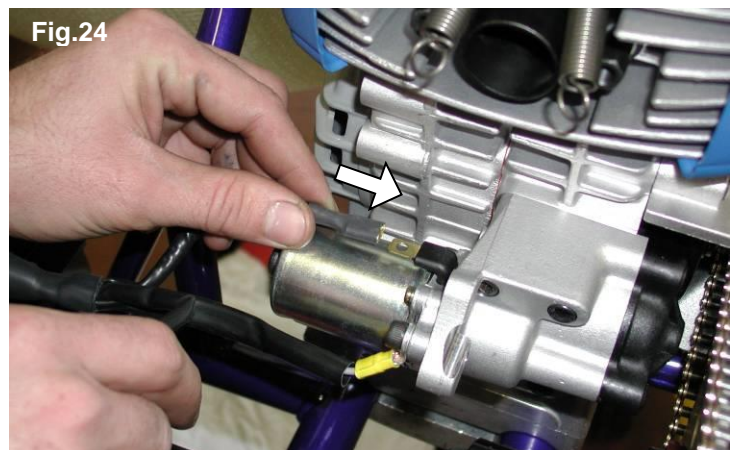

Fig.24



3.8.2 CONNECT THE TERMINAL OF THE IGNITION STATOR TO THE H.T. COIL (SEE FIG.25).



3.8.3 CONNECT THE SECOND TERMINAL OF THE IGNITION STATOR TO THE "MALE" CONNECTOR OF THE HARNESS (SEE FIG.26).



3.8.4 FIX THE HARNESS WITH PLASTIC CLAMPS, ALONG THE CHASSIS REAR RAIL (SEE FIG.27).



3.8.5 FIX THE BATTERY AND HARNESS TERMINALS BY MEANS OF THE STRAP (SEE FIG.28).



3.8.6 FIX THE STARTER RELAY TO THE FIXING STRAP BY MEANS OF A CLAMP, OR FIX IT TO THE BATTERY SUPPORT WITH THE BIADHESIVE TAPE (SEE FIG.29).



ATTENTION:
NEVER LET THE HARNESS GET IN TOUCH WITH THE GROUND OR WITH ROTATING PARTS AS IT COULD BE DAMAGED BEYOND REPAIR.

Fig.29



3.8.7 FIX THE REMAINING HARNESS ALONG THE RAIL, BRAKE SIDE, WITH PLASTIC CLAMPS. (SEE FIG.30).

Fig.30

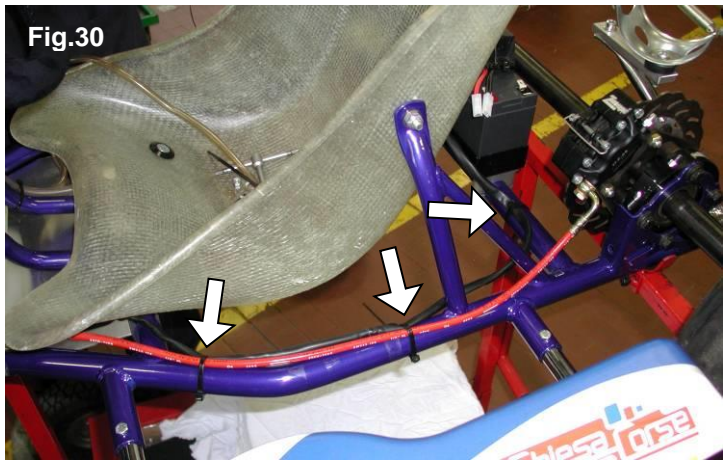

3.8.8 REMOVE THE STEERING WHEEL AND POSITION THE PUSH BUTTON SUPPORT BRACKET ON THE HUB. (SEE FIG.31).

Fig.31



3.8.9 ASSEMBLE THE PUSH BUTTONS INTO THE SUPPORT BRACKET (SEE FIG.32).

Fig.32

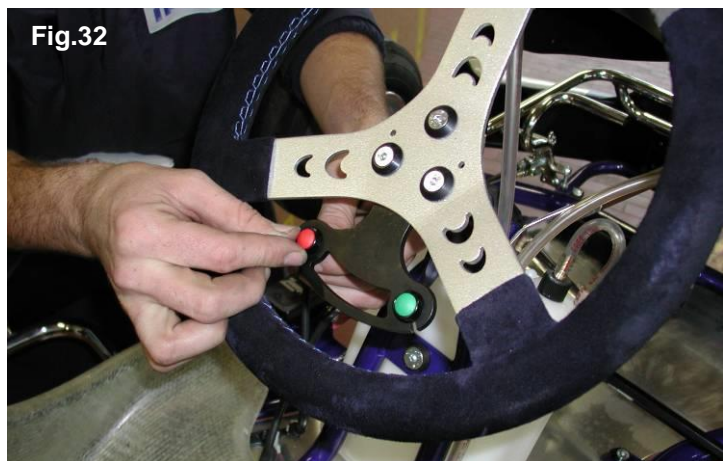

3.8.10 CONNECT THE BUTTON CONNECTORS WITH THE HARNESS CONNECTORS (SEE FIG.33).



ATTENTION:
PAY ATTENTION TO MATCH THE CONNECTORS ACCORDING TO THE CORRESPONDING COLOUR IN ORDER TO CONNECT THEM PROPERLY.

Fig.33

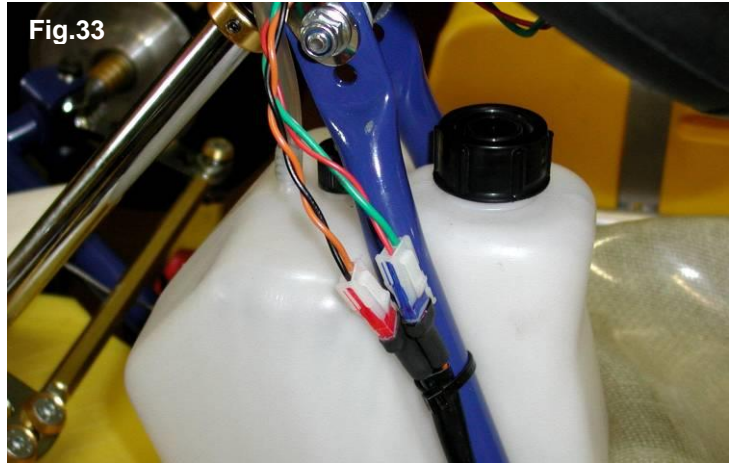

3.8.11 TIGHTEN THE SPARK PLUG CAP ON THE H.T. COIL CABLE (SEE FIG. 34).

Fig.34

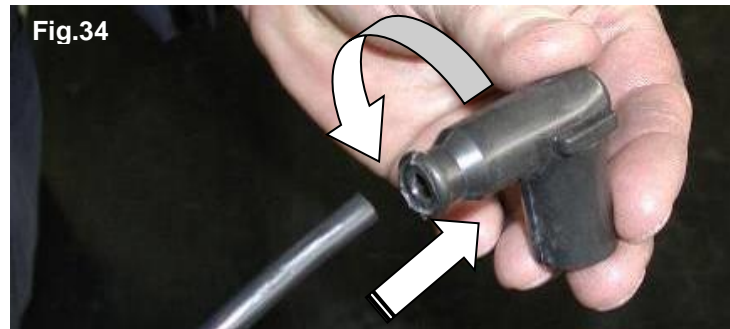

3.8.12 FIX THE SPARK-PLUG CAP ON THE H.T. CABLE WITH A PLASTIC CLAMP (SEE FIG. 35).

Fig.35

- INSTALL THE SPARK PLUG SUPPLIED WITH THE ENGINE
TORQUE AT 20 ÷ 26 Nm (175 ÷ 230 in-lb)
- POSITION THE SPARK PLUG CAP ON THE SPARK-PLUG.



Caution should be taken when installing the spark plug. Always clean and inspect the spark plug threads before installation. Always apply anti seize compound, grease or oil.

- NEVER INSTALL THE SPARK PLUG WITHOUT SOME LUBRICATION -

You should be able to freely turn the plug into the head using only your fingers to turn the plug. Do not force the plug with a tool or damage will occur. After rotating the plug into the head by hand only. Torque to 175-230 lbs-in (20÷26 Nm).

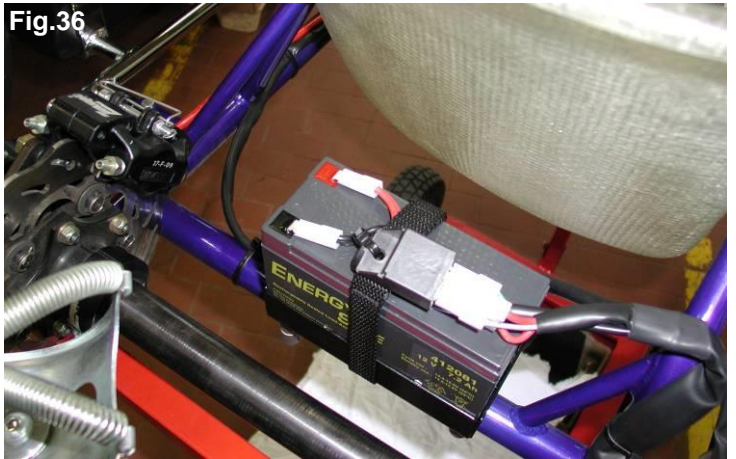
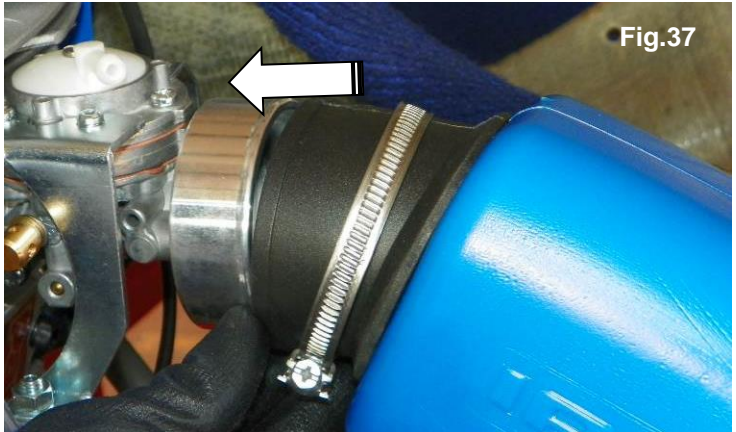
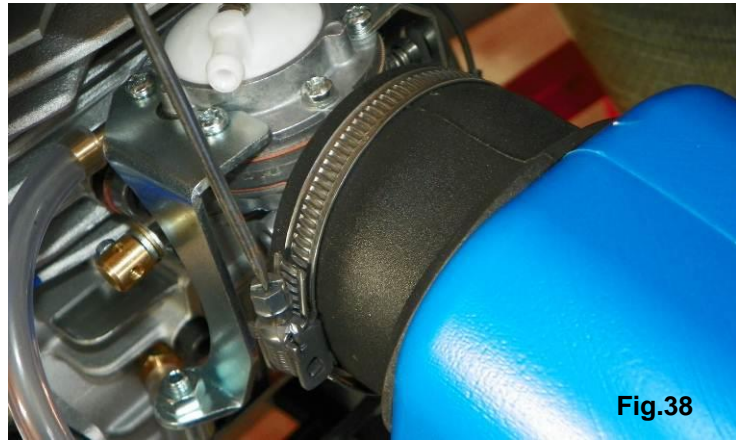
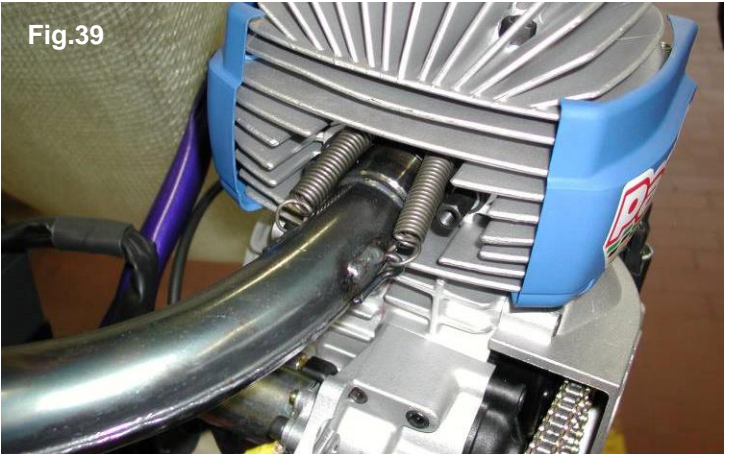

	<p>3.8.13 MAKE SURE THAT THE BATTERY IS PROPERLY CONNECTED BEFORE STARTING THE ENGINE. (SEE FIG. 36).</p>	 <p>Fig.36</p>
<p>3.9</p>	<p>INSTALL THE INTAKE SILENCER</p> <ul style="list-style-type: none"> - MAKE SURE THAT THE AIR FILTER HAS THE INLET HOLE TOWARDS UPPER SIDE AND THAT IT IS NOT PLUGGED. - TIGHTEN THE FIXING CLAMP ON THE CARB. AND FIX THE FILTER BY MEANS OF THE PROPER CLAMP ON THE CHASSIS RAIL (SEE FIG. 37-38). 	 <p>Fig.37</p>  <p>Fig.38</p>
<p>3.10</p>	<p>INSTALL THE EXHAUST SYSTEM</p> <p>INSTALL THE EXHAUST MUFFLER ON THE FITTING AND SECURE IT WITH THE 2 SPRINGS. (SEE FIG. 39).</p> <p>NOTE: <u>ON THE "BABY" VERSION, THE MUFFLER IS DIRECTLY POSITIONED ON THE CYLINDER WITHOUT ANY INTERMEDIATE FITTING</u></p>	 <p>Fig.39</p>

ENGINE IS READY TO BE STARTED



4- GASOLINE AND OIL

Use (leaded) or unleaded gasoline, mixed with oil at 6% (16:1).

Use oil containing Castor Oil which guarantees an optimized lubrication at high temperatures.

As on the other hand, use of Castor Oils creates gummy residues which give origin to carbon deposits, it is necessary to check and clean, at least every 5 ÷10 hours, the piston and the head.

Our experience dictates use of oils such as:

- WLADOIL K 2T KART RACING OIL
- SHELL ADVANCE RACING M
- ELF HTX 909

Once the fuel tank is filled, make sure that the gasoline reaches the carburetor before starting the engine.

Never use the electric starter to suck the gasoline as this would discharge the battery.

SUGGESTION:

Disconnect the plastic tube on the carb. pump and the vent tube on the tank and pressurize the vent tube, until gasoline comes out from the tube on the carb. pump. Make sure that there is no air in the tube.

Connect the tube on the carb. and on the vent.



5-TILLOTSON HW-31A CARBURETTOR ADJUSTMENT

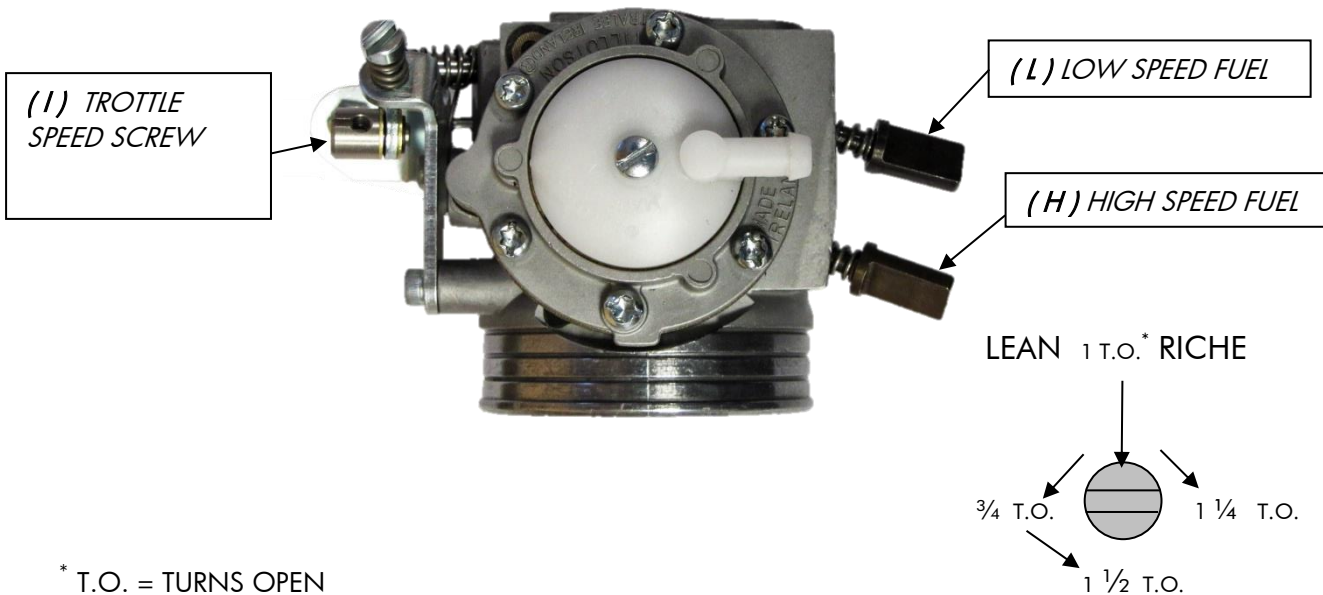

* T.O. = TURNS OPEN

Normally the correct setting of the mixture screws, after engine run-in, is the following:

- L (close the screw completely and then open): 1 T.O. + $\frac{1}{4}$ (1 turn and 15')
- H (close the screw completely and then open): $\frac{3}{4}$ T.O. (45')

Based on various factors as altitude, ambient temperature etc. It might be necessary to reset the carburettor to optimize the performance of the engine.

ATTENTION:

- *Never lean too much as lean mixture will overheat engine and cause seizure.*
- *Do not force H or L closed. It may damage the precision machined orifice and render the carb. unserviceable.*
- *The adjustment of screw must be performed with warm engine.*



6- STARTING AND STOPPING THE ENGINE

Press the green button on the steering wheel to start the engine.

If the engine cannot be started, stop and try again (check that gas gets into the carb.).

Short and frequent tries are better than long ones.

In case the engine can't be started, refer to the Sect. 17 " Troubleshooting".

The engine can be stopped by pressing the red button on the steering wheel. Keep the button pressed until the engine has got to a complete stop.

7- ENGINE BREAK-IN

The break-in of the engine must be performed following a few fundamental rules.

1. Adjust the carburetion. Start with an adjustment on the rich side.
2. Warm the engine gradually for about 5 minutes at half throttle, making some laps at low speed, closing and opening gently the carb. throttle (if a tachometer is installed never exceed 8.000 RPMs). **Never keep the same RPM for a long time.**
3. Progressively increase the speed of the kart for 5 minutes at $\frac{3}{4}$ throttle opening. **Never keep the same RPM for a long time.**
4. Increase the speed for approx. 5 minutes at max. speed, with throttle wide open and making the engine rich at half straight (cover with the hand for **an instant** the holes on the air filter, keeping the throttle wide open).



ATTENTION:

Once the break-in is over and the engine is cold, check the torque of the exhaust header nuts as, during the break-in, the nuts tend to become loose (refer to the attached table).

8- INLET SILENCER

Make sure that the inlet hole on the filter is towards the upper side and that it is not plugged. Make sure that the clamp on the carburetor is not loosen and that the filter is well fastened to the chassis rail.

Once a while, clean the inside from oil deposits. If necessary remove the rubber filter fitting and clean it with gasoline or solvent.

9- RECOMMENDATIONS ON THE EXHAUST SYSTEM

Always make sure that the springs are well hooked and in place. In case of breakage, replace the broken spring. **Never race the kart without the 2 springs in place**, as otherwise the exhaust pipe could vibrate beyond control.

Every 10÷15 hours, open the exhaust pipe end and make sure that the holes on the internal counter cone are not plugged.



10- CENTRIFUGAL CLUTCH

The engine has a low maintenance dry centrifugal clutch. The following prescriptions, if carefully followed, will allow a long clutch life.

When starting the engine, make sure that the brake pedal is fully pressed to avoid sudden accelerations.



ATTENTION:

Once the engine is started and kart is still, avoid useless accelerations which can overheat and deteriorate the clutch, before time. Oil the chain before each test, immediately after each race or test and check the engine sprocket. Replace if necessary.

A bad alignment of the engine sprocket with the axle sprocket or the lack of oil will damage the chain and sprocket.

Check the clutch:

- Every 5 hours of use.
- When metallic noises are heard inside the clutch.
- If the kart dragging speed exceeds 5000 RPMs.
- Every time the clutch has overheated (presence of smoke or smell of burning).

To check the clutch, you must remove the clutch cover and the clutch drum.

Replace the clutch

- Whenever the thickness of the friction material (see drawing) is lower than 1.5mm on Point A of the clutch or if the body diameter is lower than 82.5mm.
- Whenever the external friction material in the A portion of the clutch is very rough (wear or degradation of the friction material due to overheating).



ATTENTION:

In case the friction material has been totally worn out and there is a contact between the clutch body and the clutch drum, it is necessary to replace the clutch drum. See drawing,

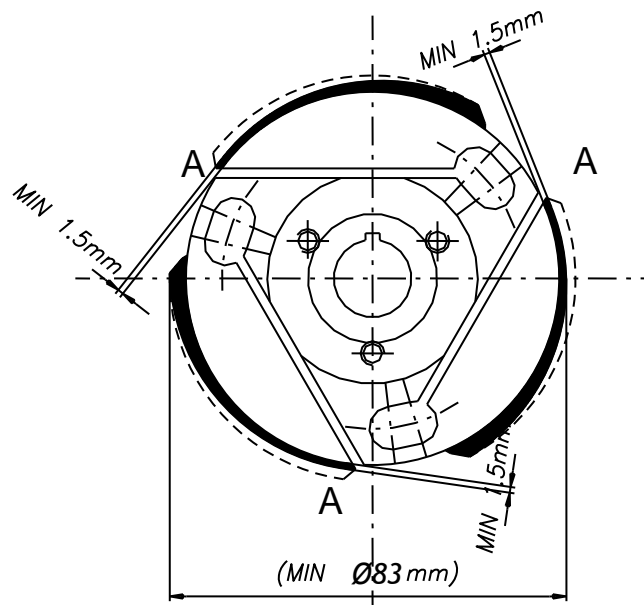

11- INSTRUCTIONS FOR THE DISASSEMBLY / ASSEMBLY OF THE CLUTCH



ATTENTION:

The following operations can be performed by a skilled mechanic under the condition to have available the dedicated tools shown on the text, otherwise it is necessary to apply to an Authorized Service Center.



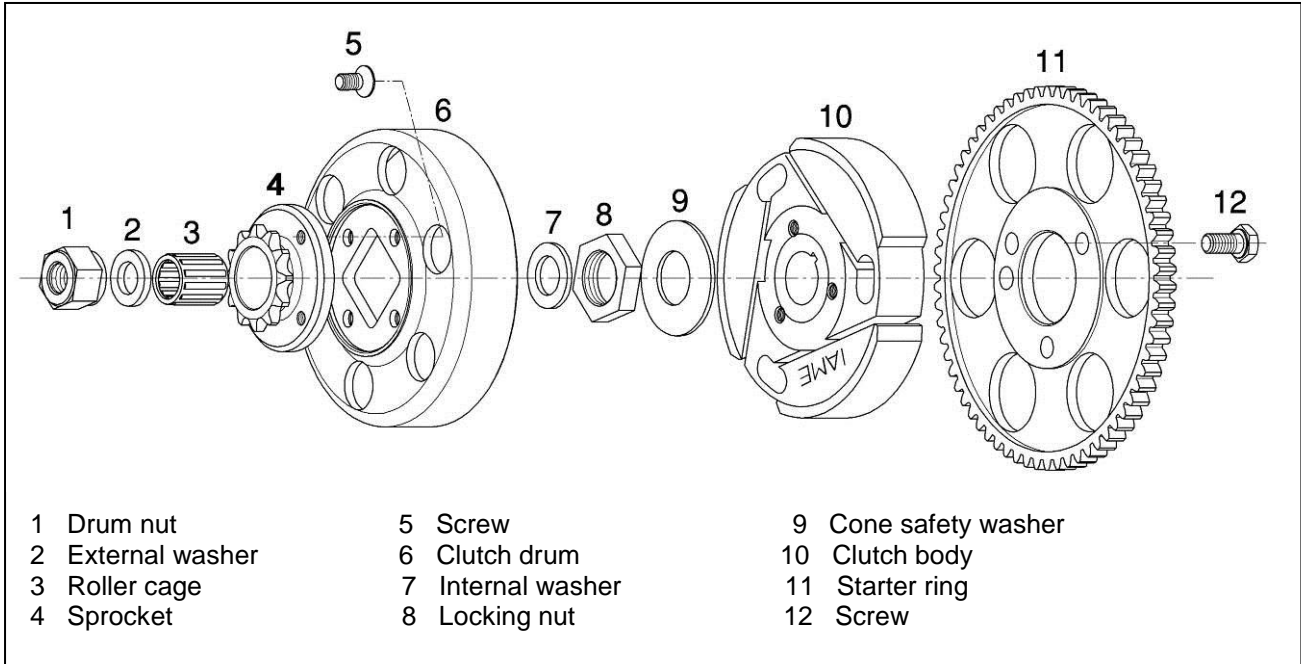

Refer to the following drawing during the operations



OPERATIONS	TOOLS
<u>Clutch disassembly</u>	
1. Remove clutch cover (3 screws M6).	▪ Allen wrench 5mm – T type
2. Remove spark plug and replace with special tool to prevent crankshaft from turning.	▪ Piston fitting: P.N. 10271
3. Remove nut (1 nut M10).	▪ 12 Point wrench - 17 mm
4. Remove the external washer, the drum with roller cage, the internal washer.	
5. Remove the special tool from the head and using the clutch wrench, remove the M16x1 nut and the cone safety washer.	▪ Clutch wrench : P.N. 10270 ▪ 24 mm socket.
! <u>ATTENTION: Turn clockwise as nut has left thread.</u>	
6. Apply clutch puller on clutch and remove clutch from the crankshaft, with 12 point wrench 19mm.	▪ Clutch puller: P.N. B-55614-C ▪ 12 Point wrench - 19mm.
7. Remove key from shaft.	
8. Remove starter ring (3 screws M6)	▪ 12 Point wrench - 10 mm



Before assembling the clutch, wash with diluent the shaft taper, the connecting hole on the clutch body, the clutch drum and the starter ring.

Clutch assembly	
<p>1. Install the starter ring on the clutch body (3 screws M6).</p> <p> ATTENTION: make sure to always install the \varnothing 7mm drag pin as, otherwise, the eventual kick backs could break the screws.</p>	<ul style="list-style-type: none"> ▪ 12 Point wrench - 10 mm (Torque at 10 Nm) (90 in-lb) (apply Loctite on the threads)
2. Insert key on shaft.	
3. Install clutch body and cone safety washer on shaft.	
<p>4. Install the M16 x1 nut using the clutch wrench.</p> <p> ATTENTION: turn counterclockwise as nut has left thread</p>	<ul style="list-style-type: none"> ▪ Clutch wrench P.N. 10270 ▪ 12 Point wrench - 24 mm. (Torque at 40 ÷ 50 Nm) (350 ÷ 440 in-lb)
<p>5. Install the internal washer .</p> <p> ATTENTION: install washer with bevel towards internal part of engine. Clean the roller cage and grease it before installing it on the crankshaft.</p>	
<p>6. Install the clutch drum and the external washer.</p> <p> ATTENTION: install washer with bevel towards internal part of engine.</p>	
<p>7. Install the piston fitting to prevent the shaft from turning and install the M10 nut.</p>	<ul style="list-style-type: none"> ▪ Piston fitting : P.N. 10271 ▪ 12 Point wrench - 17 mm (torque at 30 ÷ 40 Nm) (350 ÷ 440 in-lb)
<p>8. Install the clutch cover (3 screws M 6).</p>	<ul style="list-style-type: none"> ▪ Allen 5mm (Torque at 8 ÷ 10 Nm) (70 ÷ 90 in-lb)



12- BATTERY

The battery (12 V – 7.2 Ah) is sealed and without maintenance.

In order to lengthen the battery life it is necessary though to follow a few recommendations .

- When tension drops below 12.6V it is necessary to recharge the battery.
- Max allowed recharging current is 1.8A.
- The ideal recharge is achieved with an average charging current of $0.8 \div 1$ A. (recharging time of appr. 10 h.) and at an ambient temperature between 0° and 40°C.



ATTENTION:

An overcharge or an extremely quick recharge with excessive current could damage the battery (the battery would tend to swell).

- During transportation or storage, the battery could loose its charge due to self-discharge (0.1% max per day).
Fully recharge battery before use.



ATTENTION:

Always connect the - (negative) terminal first and the + (positive) terminal after.

Always disconnect the battery in opposite order.

- Recharge the battery at least once every 6 months.
- Never let the battery tension dropping under 8V, as whenever it drops under this limit, the battery cannot be used any longer and it has to be replaced.
- Never put the battery in contact with solvents, gasolines, oils, plastifiers or rags, containing such elements. The external case of the battery could be damaged.
- Never press or bend or overheat (by welding) the battery terminals.

Other recommendations

- Pay attention to avoid free fires upon or around battery.
- Never short-circuit the terminals.
- Never open the battery or throw it in the fire.
- In case the electrolyte (diluted Sulfuric Acid) gets in contact with skin or clothes, immediately wash with water. In case it gets in touch with eyes, wash and apply for medical assistance.
- Carefully check the external case of battery and replace in case of breakages, swellings of the case or of battery cover.
- Before use, clean the battery from dust and check that the terminals are not oxidized or damaged.
- When the battery comes to an end never throw it in the garbage but deliver it to an authorized disposer.



13- USE OF THE BATTERY CHARGER (OPTIONAL)



ATTENTION:

The electric system of the PARILLA 60cc MINI SWIFT and BABY SWIFT engines does not charge the battery.

Therefore to properly charge the battery, supplied with the engines, we recommend you the **battery charger, P.N. A-120910 (not included in the supply).**

This battery charger, which has been expressly selected by IAME for its characteristics, operates at 220V, is easy to use, and, automatically switches off when the charging is over.

INSTRUCTIONS FOR USE

1. Connect the red plug of the battery charger to the terminal " + "(red) of the battery and the blue plug to the terminal " - " (black).
2. Plug-in the battery charger to a 220 V – 50 hz current tap.
3. When charging, the red led of the battery charger is lightened. When the battery is fully charged, the red led is off.
4. Recharging time of a completely discharged battery : approx 7÷8 hrs.



ATTENTION

Do not keep the battery charger connected for a long time after the led is off, to avoid overheating the charger.



ATTENTION

When connecting the battery charger, pay attention not to reverse the polarity of the connections, otherwise the battery charger and/or the battery might be damaged .

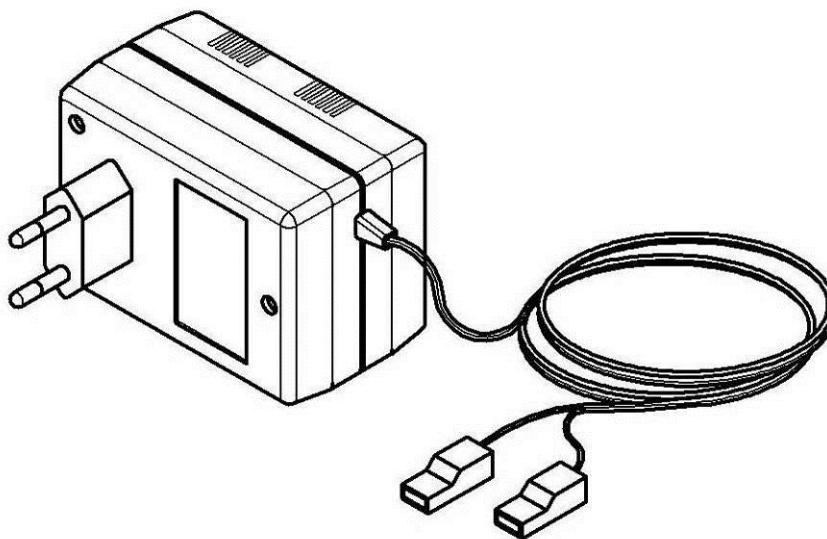



14 –SPARK-PLUG THERMAL DEGREE

The engine is supplied with a standard **NGK BR10EG** spark plug which represents a good compromise between the needs of a good break-in and the racing needs in normal conditions.

Use of different spark plugs is possible and, as a general information, we are attaching a correspondence list among spark plugs of other brands, based on **thermal degree**, which represents the capacity of the spark plug to dissipate the internal heat. The colour of the various parts of the spark plug more exposed to the combustion flames gives a good indication on the adequacy of the thermal degree and on the carburetion. It is necessary though to understand which of the two parameters has to be changed and only the experience tells how to identify the most proper thermal degree of a spark plug as lean or rich mixtures can generate the same final look which can be also achieved with a hot or cold spark plug.

See table:

<p>an excessively warm spark plug shows the symptoms listed aside.</p> <p> ATTENTION: <i>Always use a warmer than standard spark plug with cold or rainy climates</i></p>	<ul style="list-style-type: none"> ▪ Extremely clear color, porous look and calcification of the electrodes and of the internal insulation. ▪ Irregularities in the ignition, preignition and detonation with tendency to perforate the top of the piston . ▪ Note: some of these symptoms can be achieved with lean mixtures.
<p>A correct thermal degree shows:</p>	<ul style="list-style-type: none"> ▪ Color of the insulator end from yellow grey to dark brown for mixtures respectively lean or rich.

<p>An excessively cold spark plug shows the symptoms, listed aside.</p> <p> ATTENTION: <i>Always use a colder than standard spark plug with hot climates.</i></p>	<ul style="list-style-type: none"> ▪ Insulator end and electrodes covered with black shady soot. ▪ Ignition difficulties. ▪ Note: a wet or oily electrode could also mean an excessively rich mixture.
--	--

COMPARISON TABLE BASED ON THE THERMAL DEGREE HOT



BOSCH	NGK	CHAMPION
WO8CS	BR9EG	N54R
WO7CS	BR10EG	N52R
WO6CS	BR11EG	



COLD



15- CHOICE OF THE BEST SPROCKET RATIO

The life of an engine depends upon many factors but most of all upon the speed at which the engine is operated. If an engine is normally operated at speeds higher than what recommended by the manufacturer, the wears and stress of the various components (con-rods, cages, bearings etc.) will be such as to drastically reduce the life of engine itself. It is therefore extremely important that the user respects the operating limits imposed by the manufacturer.

The operating limit for the 60 MINI SWIFT engine is 14.500 RPM.



ATTENTION:

Never exceed the above limit. No obligation of IAME exists in case the above limit is exceeded.

In case the user wishes to optimize on the track the sprocket ratio in order to achieve the best possible performance, without abusing the engine, follow the under shown recommendations.

The engines are supplied with a 11 teeth sprocket (pitch 7.775 mm.) Table 1 shows the various ratios between the sprocket on the axle and the engine sprocket, given the different axle sprockets.

Tab.1

Sprocket ratio	Teeth n° - Engine sprocket	Sprocket ratio	Teeth n° - Engine sprocket
Teeth n° Axle sprocket	11	Teeth n° Axle sprocket	11
72	6,55	83	7,55
73	6,64	84	7,64
74	6,73	85	7,73
75	6,82	86	7,82
76	6,91	87	7,91
77	7,00	88	8,00
78	7,09	89	8,09
79	7,18	90	8,18
80	7,27	91	8,27
81	7,36	92	8,36
82	7,45		

For the operation limit of 14.500 RPMs, the following table (Tab. 2) has been prepared.

SUGGESTION

- **During the track tests we recommend the use of a tachometer recording the max obtained engine RPMs.**
- **Use spark plug caps with a resistance of 5K Ω to avoid interferences between the engine ignition and the tachometer and/or telemetry.**

The following example should clarify the procedure for the optimization of the sprocket.



Assume to use the engine with Z=11 teeth sprocket and that during the preliminary tests a Z=72 teeth axle sprocket has been used.

- From Table 1 with Z=11 as engine sprocket and Z=72 on the axle sprocket, a ratio of 6.55 is found.
- Make a few laps on the track and, record the max RPMs achieved by the engine. Assume that we read 12.000 RPMs.
- From the Table 2 to achieve a max. RPM 14.500 (operating limit for the MINI SWIFT engine) a sprocket ratio of 7.85 should be used (having used, during the tests, a sprocket ratio of 6.55 and having achieved 12.000 RPMs).
- From Table 1, to achieve a sprocket ratio of 7.85, a Z=86 teeth axle sprocket should be used.

Sprocket ratio to achieve max. 14.500 RPM															Tab. 2
Engine max. RPM during tests	Sprocket ratio														
	5,9	6,1	6,3	6,5	6,7	6,9	7,1	7,3	7,5	7,7	7,9	8,1	8,3	8,5	
12000	7,13	7,37	7,61	7,85	8,10	8,34	8,58	8,82	9,06	9,30	9,55	9,79	10,03	10,27	
12200	7,01	7,25	7,49	7,73	7,96	8,20	8,44	8,68	8,91	9,15	9,39	9,63	9,86	10,10	
12400	6,90	7,13	7,37	7,60	7,83	8,07	8,30	8,54	8,77	9,00	9,24	9,47	9,71	9,94	
12600	6,79	7,02	7,25	7,48	7,71	7,94	8,17	8,40	8,63	8,86	9,09	9,32	9,55	9,78	
12800	6,68	6,91	7,14	7,36	7,59	7,82	8,04	8,27	8,50	8,72	8,95	9,18	9,40	9,63	
13000	6,58	6,80	7,03	7,25	7,47	7,70	7,92	8,14	8,37	8,59	8,81	9,03	9,26	9,48	
13200	6,48	6,70	6,92	7,14	7,36	7,58	7,80	8,02	8,24	8,46	8,68	8,90	9,12	9,34	
13400	6,38	6,60	6,82	7,03	7,25	7,47	7,68	7,90	8,12	8,33	8,55	8,76	8,98	9,20	
13600	6,29	6,50	6,72	6,93	7,14	7,36	7,57	7,78	8,00	8,21	8,42	8,64	8,85	9,06	
13800	6,20	6,41	6,62	6,83	7,04	7,25	7,46	7,67	7,88	8,09	8,30	8,51	8,72	8,93	
14000	6,11	6,32	6,53	6,73	6,94	7,15	7,35	7,56	7,77	7,98	8,18	8,39	8,60	8,80	
14200	6,02	6,23	6,43	6,64	6,84	7,05	7,25	7,45	7,66	7,86	8,07	8,27	8,48	8,68	
14400	5,94	6,14	6,34	6,55	6,75	6,95	7,15	7,35	7,55	7,75	7,95	8,16	8,36	8,56	
14600	5,86	6,06	6,26	6,46	6,65	6,85	7,05	7,25	7,45	7,65	7,85	8,04	8,24	8,44	
14800	5,78	5,98	6,17	6,37	6,56	6,76	6,96	7,15	7,35	7,54	7,74	7,94	8,13	8,33	
15000	5,70	5,90	6,09	6,28	6,48	6,67	6,86	7,06	7,25	7,44	7,64	7,83	8,02	8,22	
15200	5,63	5,82	6,01	6,20	6,39	6,58	6,77	6,96	7,15	7,35	7,54	7,73	7,92	8,11	
15400	5,56	5,74	5,93	6,12	6,31	6,50	6,69	6,87	7,06	7,25	7,44	7,63	7,81	8,00	
15600	5,48	5,67	5,86	6,04	6,23	6,41	6,60	6,79	6,97	7,16	7,34	7,53	7,71	7,90	
15800	5,41	5,60	5,78	5,97	6,15	6,33	6,52	6,70	6,88	7,07	7,25	7,43	7,62	7,80	
16000	5,35	5,53	5,71	5,89	6,07	6,25	6,43	6,62	6,80	6,98	7,16	7,34	7,52	7,70	



16- SCHEDULED MAINTENANCE

Following some simple maintenance standards will allow to perform more reliably and guarantee a longer engine life.

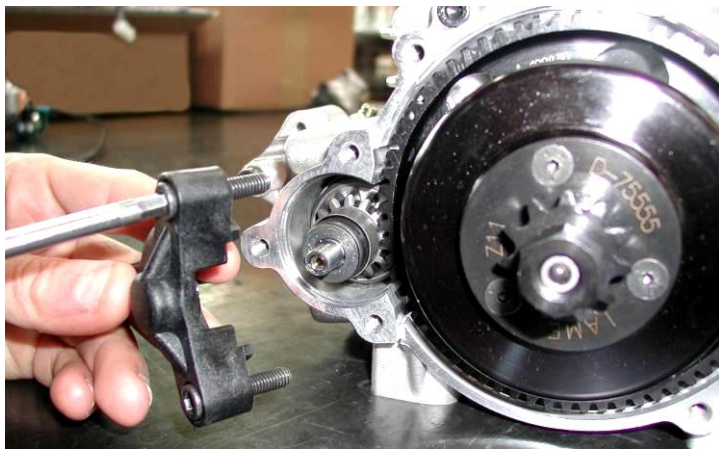
SCHEDULE	COMPONENTS	ACTIONS AND COMMENTS
Before using	Exhaust	Check status and fixing
	Engine sprocket	Check wear Check alignment with axle sprocket
	Engine chain	Check wear, tensioning and oil chain
	Battery	Check status and charge
	Cables and connectors	Check status and connections
	Engine mount and clamps	Check torques
After use	Battery	Disconnect
	Chain	Check status and oil chain
	Engine	External cleaning
Every 5 ÷ 10 hours	Bendix assembly	Remove cover (see fig.) and clean internally
		
	Exhaust muffler	Remove muffler end, clean
	Inlet silencer	Open, clean
	Engine head	Open, clean
	Clutch	Open and check status of parts
Every 20 hours	Piston and con-rod assembly	Check and replace worn parts
	Crankshaft	Check and replace worn parts
	Ball bearings	Check and replace worn parts



17- TROUBLESHOOTING

Below are some common faults, their probable causes and suggested remedy .

Faults	Probable causes	Remedy
Starter will not crank when pushing the start button	Bad connections on starter cables.	Check and tighten
	Bad grounding of wiring loom	Check connections and tighten
	Damaged cables	Replace
	Battery connection loose	Check and tighten
	Battery discharged	Recharge battery
	Starter failure	Check
	Failed relay	Replace
Starter cranks but engine won't start	Damage START button	Replace
	Ignition failure	Replace
	Bad H.T. coil connection or coil failure	Check / replace
	Bad H.T. coil grounding	Check grounding
	Wet or damaged spark plug	Replace
Rough idle	Malfuction on feed system	Check status and connections on fuel pipe Replace membranes and gaskets on fuel pump
	Bad carb. adjustment (L screw)	Check carb. adjustm. (see sect. 5)
Drop in engine performance	Bad compression	Check piston status
	Bad carb. adjustment	Check carb. adjustm. (see sect. 5)
	Insufficient gas fuel flow	Ckeck gasoline flow lines
	Dirty inlet silencer or filter	Check and clean
Burning smell, smoke	Overheating of clutch	Check clutch status (see sect. 11)
Clutch engages at too high RPMs	Excessive wear of friction material	Check clutch status (see sect. 11)
	Oil or grease into the clutch drum	Cleaning / Replace clutch hub
Exhaust too noisy	Springs damaged or lost	Check and replace if necessary
	Damaged exhaust	



18- ENGINE PRESERVATION

When engine has to remain unoperative for a long period it must be preserved as follows :

- Disconnect the battery and charge it periodically (see sect. 12).
- Disconnect carburetor and clean it.
- Seal with tape the engine inlet and exhaust.

The external of the engine must be cleaned. Spray with protective oil the steel parts subject to oxidation.

Keep the engine in a dry ambient.

FASTENER TORQUE VALUES					
NOMINAL SIZE	Q.TY	FASTENER NAME	WRENCH	VALUES(Nm)	VALUES(in·lb)
M14 x 1.25	1	Spark plug	Hex.20.8	20 – 26	175 – 230
M8 x 1.25	4	Head and cylinder nut	Hex. 13	18 – 22	160 – 190
M6 x 1	2	Exhaust nut	Hex. 10	9 – 11	80 – 100
M6 x 1	2	Carb. fitting fixing screw	Allen 5	8 – 10	70 – 90
M6 x 1	2	Fuel pump fixing screw	Allen 5	8 – 10	70 – 90
M5 x 0.8	3	Coil attach. screw	Allen 4	5 – 6	45 – 50
M6 x 1	3	Ignition cover screw	Allen 5	8 – 10	70 – 90
M5 x 0.8	2	Ignition stator fixing screw	Allen 4	5 – 6	45 – 50
M10 x 1	1	Ignition rotor fixing nut	Hex. 17	20 – 26	175 – 230
M6 x 1	4	Starter support fixing screw	Allen 5	8 – 10	70 – 90
M6 x 1	3	Counter shaft support screw	Allen 5	6 – 8	50 – 70
M6 x 1	3	"Bendix" support screw	Allen 5	6 – 8	50 – 70
M6 x 1	3	Clutch cover attach. screw	Allen 5	8 – 10	70 – 90
M10 x 1	1	Clutch drum fixing nut	Hex. 17	30 – 40	265 – 350
M16 x 1	1	Clutch fixing nut	Hex. 24	65 – 75	575 – 665
M5 x 0.8	4	Engine sprocket fixing screw	Allen 3	6 – 8	50 – 70
M6 x 1	3	Starter ring fixing screw	Hex. 10	9 – 11	80 – 100
M6 x 1	4	Engine tag fixing screw	Allen 5	5 – 6	45 – 50
M6 x 1	7	Crankcase fixing screw	Allen 5	8 – 10	70 – 90
M8 x 1	1	Pressure fitting on crankcase	Hex. 11	10 – 13	90 – 120



