

# IAME

THE HEART OF KART



## ***OVERHAUL MANUAL***

## ***REEDJET 100cc -TAG***



## INDEX

ENGINE DISASSEMBLY	1
CRANKSHAFT DISASSEMBLY/ ASSEMBLY	7
CRANKSHAFT DISASSEMBLY OPERATIONS	7
CRANKSHAFT ASSEMBLY OPERATIONS	8
ENGINE ASSEMBLY	10
<u>ATTACHMENTS</u>	
- FASTENER TORQUE VALUE	20
- CROSS PATTERN LOCKING ORDER ON CRANKCASE	20
- MAIN PRESCRIPTIONS	21
- WEAR STATUS EVALUATION TABLE FOR BEARING AND CRANKSHAFT	22
- LITTLE/BIG END CONROD BEARING CLEARANCE	23
- OVERHAUL TOOLS LIST	24
- FIXING TOOL ON BENCH VISE	25
- DRAWING S725/1	26
- WIRING DIAGRAM	27



## ENGINE DISASSEMBLY

Insert n°2 screws M8x60 on bottom of crankcase to position and fix motor on bench.  
(TOOLS FOR VISE ON BENCH - FOR TOOL SEE ATTACHED DRAWING S725/1)

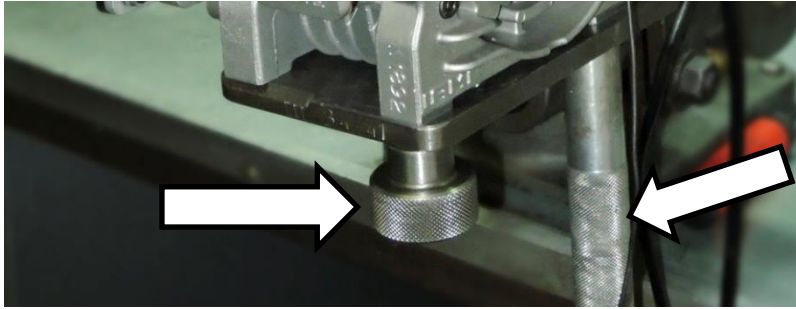

### Remove Spark Plug

Unscrew with 20.8 HINGED PLUG BOX WRENCH – T TYPE, extract the sparkplug from the engine.

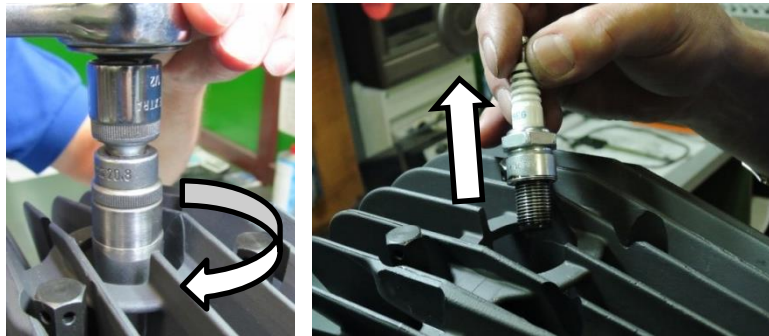

### Remove the Exhaust Manifold

Unscrew n°2 Column Nuts M8, 12 POINT WRENCH 13MM, remove n°2 washers, the exhaust manifold and its gasket.



### Remove The Clutch Cover

Unscrews n°3 M6x30 TCEI with 5mm ALLEN WRENCH – T TYPE.



## Remove The Clutch

Unscrew the Bendix cover with 5mm ALLEN WRENCH – T TYPE and remove it.

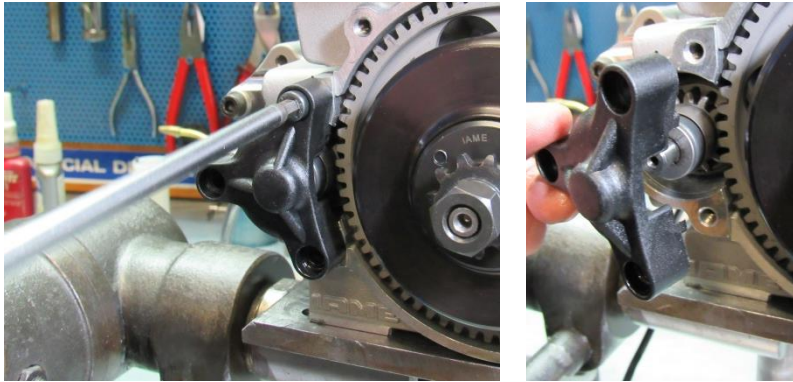

Insert the ATT.037 – STARTER WHEEL LOCKING TOOL for blocking the crankshaft rotation.



Remove the retain M10 Nut with RING WRENCH 17mm and remove subsequently the external washer, the complete drum with the roller cage, the internal washer.

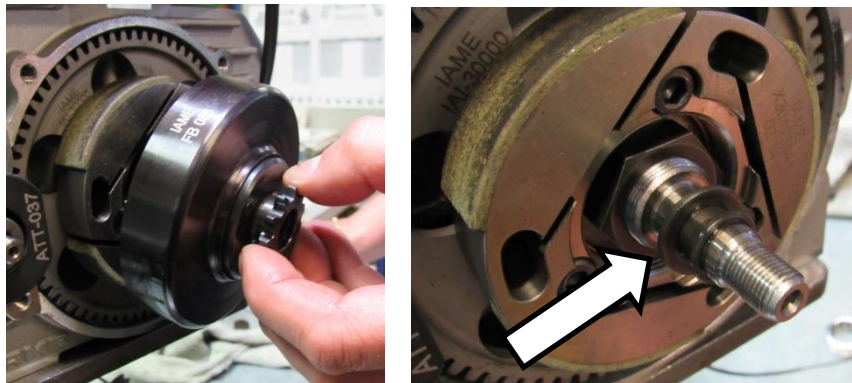

With the starter wheel locking tool and ALLEN WRENCH 27mm, remove the M20x1 clutch hub nut.

**WARNING: UNSCREW CLOCKWISE AS THE NUT HAS LEFT-HAND THREAD.**



Remove the clutch hub and the starter wheel from the crankshaft through ATT.026 CLUTCH PULLER and extract the Bendix.

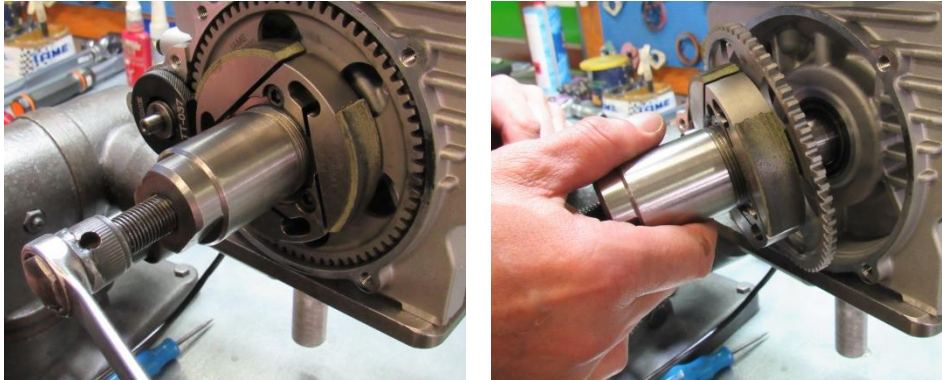

Remove the starter wheel, unscrew n°3 M6 TCEI with ALLEN WRENCH 5mm – T TYPE



### Remove The Ignition

If you have to disassemble only the ignition, is possible remove only the Bendix cover on the clutch side as in photo. The important is that the ATT.037 STARTER WHEEL LOCKING TOOL is on the place of the crankcase.

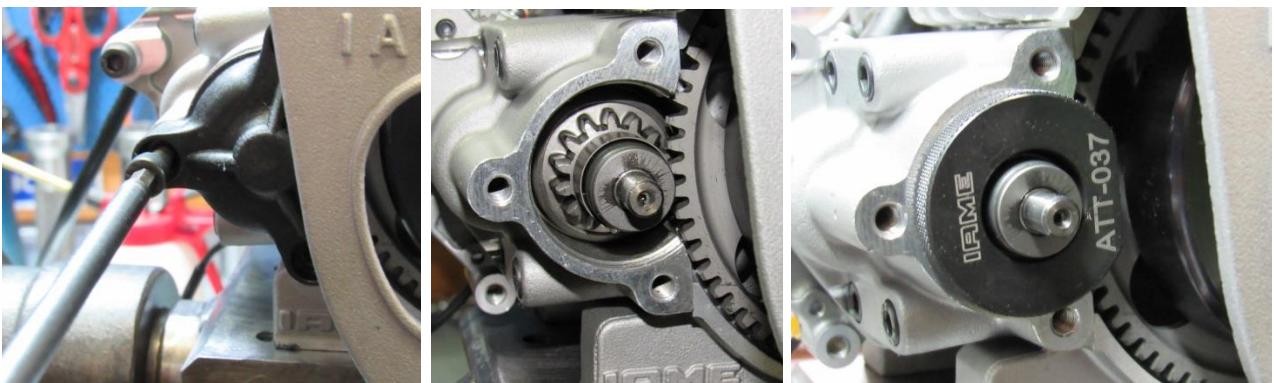

Remove the ignition retain Nut M10 with the Ring Wrench 17mm. Remove the Rotor.



Remove the Stator, unscrew n° 2 TCEI M5x25 and remove its washers. Remove ATT.037

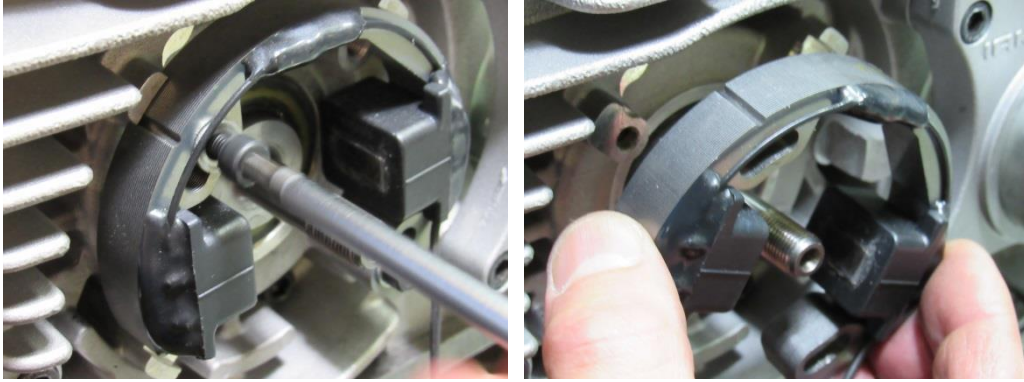

Remove the Carburettor Manifold, Outer Reed Pack Gasket, Reed Pack and Inner Reed Pack Gasket.

Remove the Carburettor gasket, unscrews n°4 TCEI M6x25 with ALLEN WRENCH 5mm T TYPE.  
Remove the other component of inlet system as in picture.

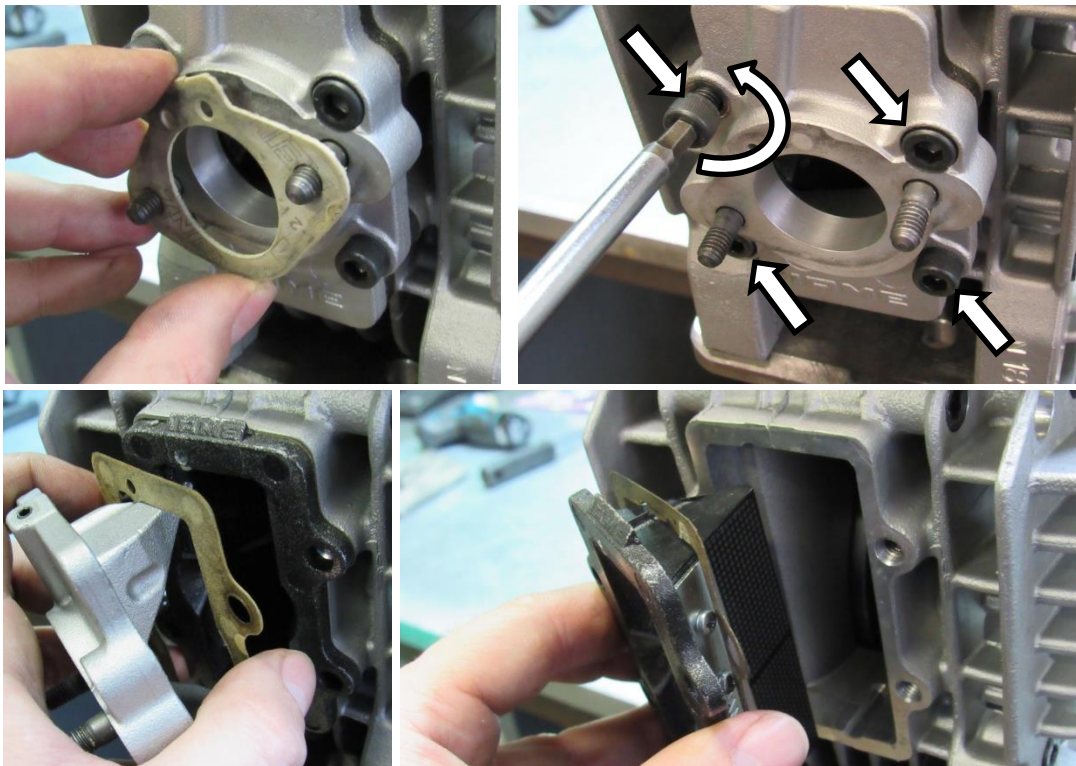

Remove the Cylinder Head

Unscrew Head Nuts, n°2 Nuts M8 and n°2 Column nuts with SOCKET WRENCH 13MM T-TYPE



Remove Cylinder O-Ring Ø60mm , remove de Spring Cable, remove Cylinder and its gasket.

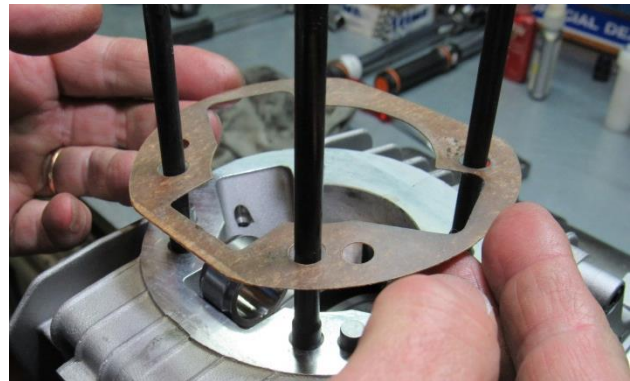
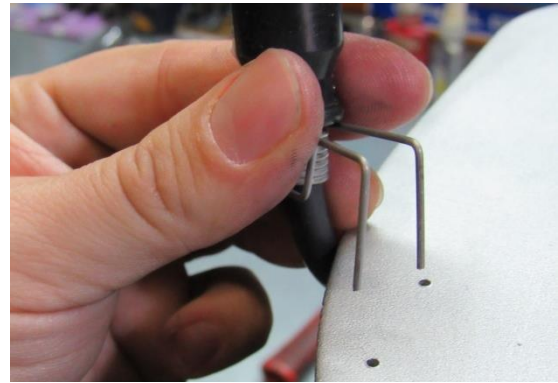
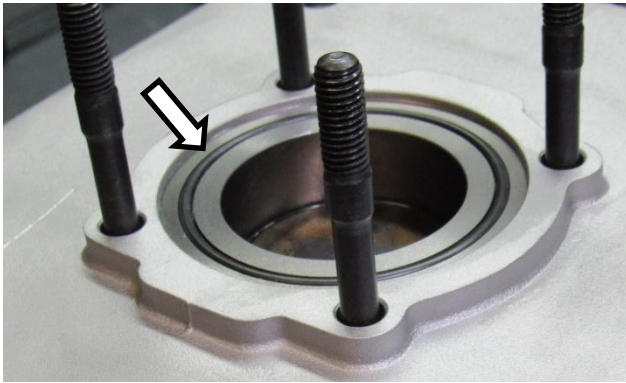

Remove the Circlips from Piston

Use a Screwdriver with rounded edges.

**ATTENTION: DO NOT SCRATCH PISTON OR CIRCLIP SEATS.**



Remove Piston Pin, Piston and Cage

Using the PISTON PIN PUNCH - P.N.10200



### Remove Starter Group

Untighten the screws that fix the starter support to the engine. Unscrew also the other screws that fixing the Bendix support to the engine.

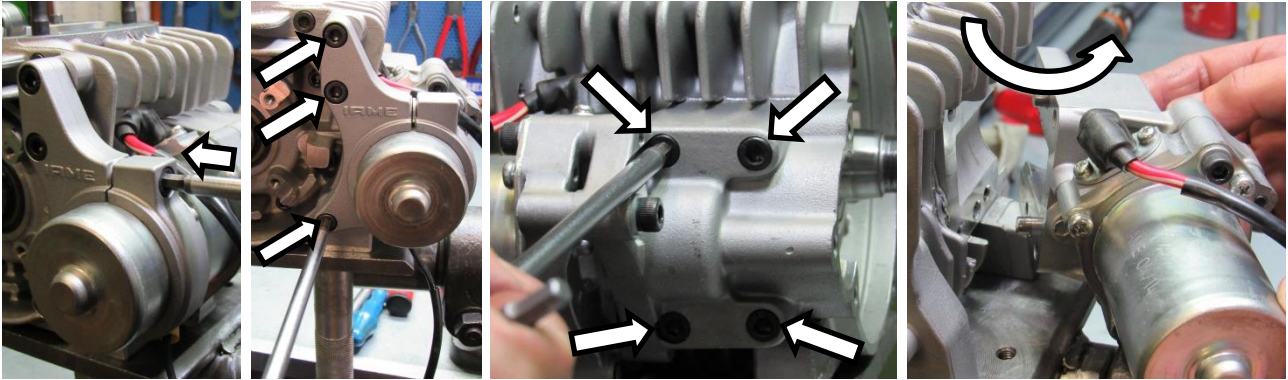

### Opening The Crankcase

Remove 7 fixing Screws (n°5 M6x45 n°3 M6x60), unscrew with ALLEN WRENCH 5mm.  
Open the crankcase using a PLASTIC MALLET.

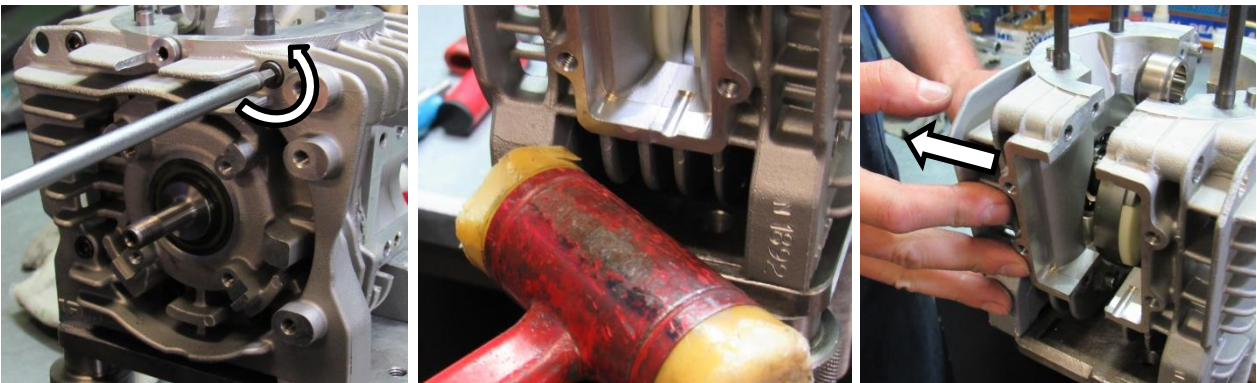

### Remove Oil Seals / Bearing if necessary

Use a SCREWDRIVER for Seals. For the bearing, heat half crankcase at 70° or use press and special pusher as in picture S725/1.

**N.B. Remove and preserve Shims**





## CRANKSHAFT DISASSEMBLY / ASSEMBLY

### ATTENTION:

THE DISASSEMBLY/ASSEMBLY OPERATIONS ON THE CRANKSHAFT, MUST BE PERFORMED ONLY BY AN AUTHORIZED SERVICE CENTER USING THE SPECIALLY DESIGNED TOOLS. USE OF UNFITTED TOOLS OR PERFORMED OPERATIONS BY UNSKILLED PERSONNEL MAY DAMAGE THE CRANKSHAFT BEYOND REPAIR.

TOOLS DESCRIPTION	N° PART
CRANKSHAFT ASSEMBLY KIT	10110A
CRANKPIN BUSH ( INCLUDED IN 10110A)	10150A
<b>CRANKSHAFT DISASSEMBLY KIT INCLUDES</b>	<b>10100-C2</b>
- CRANKSHAFT SUPPORT/ DISASSEMBLY TOOL	10100
- CRANKSHAFT PLATE / DISASSEMBLY TOOL	10104A
- CRANKSHAFT INSERT	10106
- CRANKPIN PUSHER	10107

### CRANKSHAFT DISASSEMBLY OPERATIONS

Place the disassembly tool under the press (5 MeT PRESS and disassembly KIT P.N. 10100). Place the crankshaft plate (P.N. 10104A) between the crankshaft halves. After insert the crankshaft insert (P.N. 10106) and using the crankpin pusher (P.N. 10107) press the crankpin out.



Disassemble the complete conrod with washers. Repeat the operations to extract the crankpin from the other half crankshaft.

### BEFORE REASSEMBLING, WASH ALL PARTS WITH KEROSENE

**IMPORTANT:** IF THE DISASSEMBLED PARTS AREN'T BRAND NEW AND WILL BE REASSEMBLED WITHOUT SUBSTITUTION, THEY MUST BE PLACED IN THE SAME SENSE / POSITION AS BEFORE.

WE SUGGEST TO MARK CONROD AND WASHES BEFORE DISASSEMBLE, AND PARTICULAR ATTENTION HAS TO BE PAID TO THE ROLLER CAGE, WHOSE ROLLERS CAN FALL IF CRANKPIN OR SOMETHING SIMILAR IS NOT PRESENT INSIDE CAGE ITSELF.

a) CHECK STATUS OF CONROD-TOP AND BOTTOM. IF OVALIZATION EXCEEDS 0.01mm. REPLACE CONROD.	-0.01 centesimal micrometre (21/50) -0.001 bore gauge with check ring $\varnothing$ 24 and $\varnothing$ 18 diam.
b) CHECK STATUS OF ROLLER CAGE (BIG END) VISUAL CHECK – <u>REPLACE IF NECESSARY BUT ALWAYS AFTER 30 HEURES OF WORKING REPLACING CAGE WITH PIN AND WASHERS.</u>	
c) CHECK STATUS OF CRANKSHAFT HALVES. <u>REPLACE IF BEARING SEAT DIAMETER IS BELOW 0.030mm VS. NEW.</u>	
d) CHECK STATUS OF SILVER WASHERS VISUAL CHECK – <u>REPLACE IF NECESSARY.</u>	

***FOLLOW ATTACHED TABLE FOR MAX. CLEARANCE FOR CON-ROD, CRANKPIN, CAGE.***



## CRANKSHAFT ASSEMBLY OPERATIONS

Place the crankshaft assembly tool P.N. 10110A under the press (5MeT Press), vertically. Place the half crankshaft into the assembly tool. Oil Crankpin and crankpin hole on crankshaft.

Place crankpin with crankpin bush (P.N. 10150A) on half crankshaft.

**BE SURE THAT CRANKPIN IS WELL CENTERED INTO ITS HOLE ON CRANKSHAFT.**

Bring upper plate of tool in contact with crankpin.

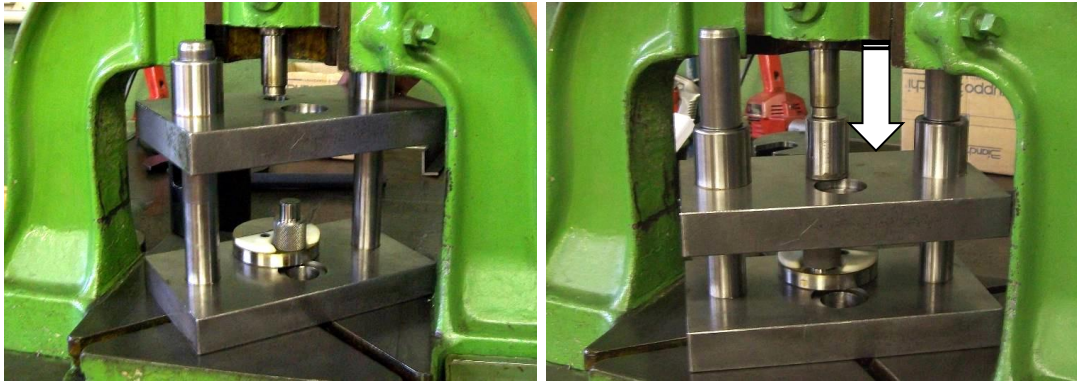

Progressively press until crankpin is completely driven in. After extract bush from crankpin and put in horizontal position.

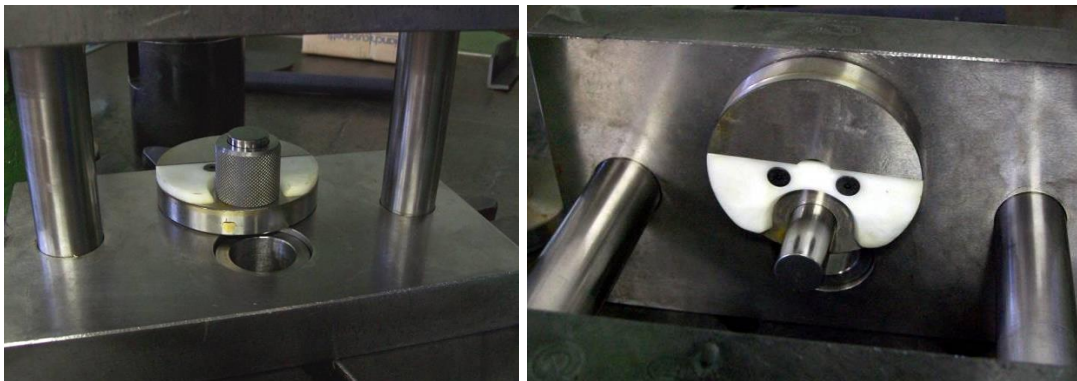

After have lubricated crankpin, insert the silver washer, the conrod with roller cage and the other silver washer.

**ATTENTION:  
ROLLERS ARE FREE IN THE CAGE, PREVENT ROLLERS FROM FALLING WHEN INSERTING  
ON CRANKPIN**



Place second half crankshaft in the seat of the counter plate. Bring the two plates close until the tool is hand pressed.

**BE SURE THAT CRANKPIN IS WELL CENTERED INTO ITS HOLE ON CRANKSHAFT**

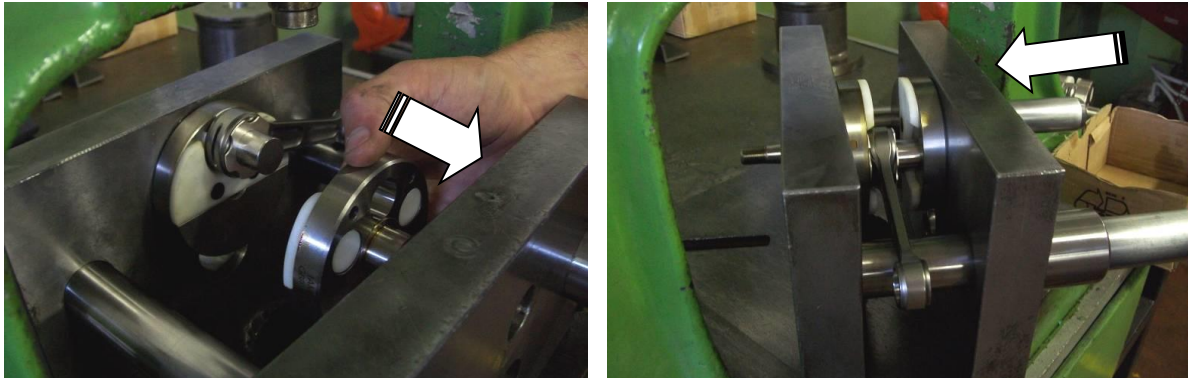

Oil crankpin and crankpin hole on half crankshaft. Put tool in vertical position. Progressively press the two crankshaft halves together. Open the tool, put it in horizontal position and extract the crankshaft.



Check the axial clearance of the conrod, it must be **MIN. 0.4mm / MAX. 0.6mm**

**IF CLEARANCE IS HIGHER OR LOWER, REBUILD THE CRANKSHAFT**

**AFTER ASSEMBLING, THE CRANKSHAFT MUST BE ALIGNED. OTHERWISE RESULT EXCESSIVE VIBRATION, HARD STARTING OR POOR ACCELERATION.**

Place the crankshaft between the centres with dial gauges indicators reading on left and right bearing seats. Use the copper hammer to align the crankshaft (if necessary). Rotate crankshaft and look at deflection of gauge needles. The deflection must be, after centring, **MAX. 0,01mm**.

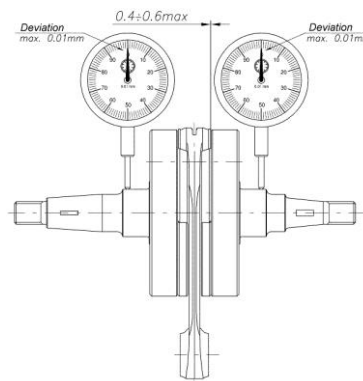
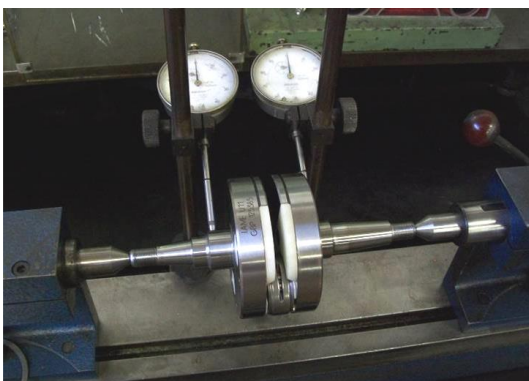

## ENGINE ASSEMBLY

**Before re-assembling, wash all parts with kerosene / diluent**

### Crankcase Assembly

Check status of crankcase bearing, replace after 30 hours suggested or 60 hrs max. Place crankcase halves under press (use tool as per drawing S 725 / 1).

Or better heat half crankcase at 70°C. If necessary insert the bearing shims.

Insert the bearing, the balls have to be on upper side and visible during the assembly (for both halves).

Then, insert the crankshaft as was positioned in the original installation and close temporarily the crankcase for axial clearance check.

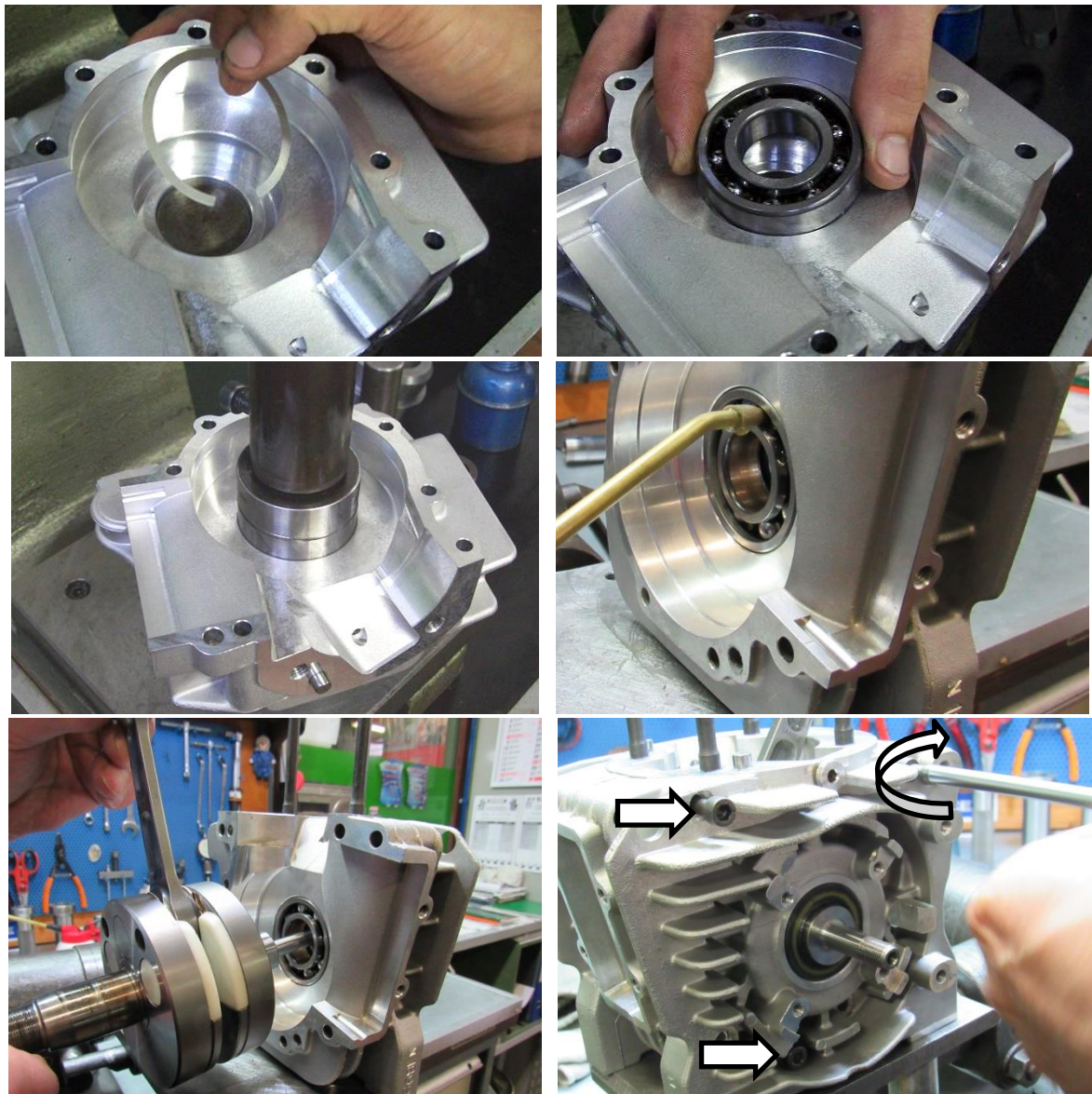

Fixing the crankcase with only 3 / 4 screws with 5mm ALLEN WRENCH – T-TYPE

In this step, tighten the screw in way no definitely 8 Nm (70 lb-in). Check the Axial Clearance.



## Check the Axial Clearance

For the check must use a check tool for crankshaft axial clearance as in picture. The clearance must be between 0.25÷0.35mm. If lower or higher disassemble the crankcase, extract the bearing and use different steel shims (0.10/0.15/0.20) to recover clearance. Shims must be equally positioned.

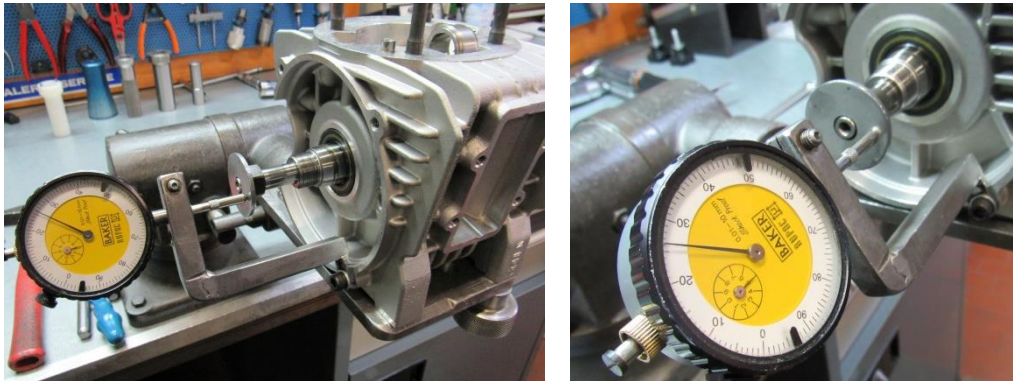

Once the correct clearance is achieved, disassemble the crankcase cleaning the surface with diluent and apply fluid gasket (Motorseal or equivalent) on one side of halves crankcase. Be careful to clean eventual excess of product. Lubricate crankshaft seat before insertion, prevent oil from fall onto liquid gasket

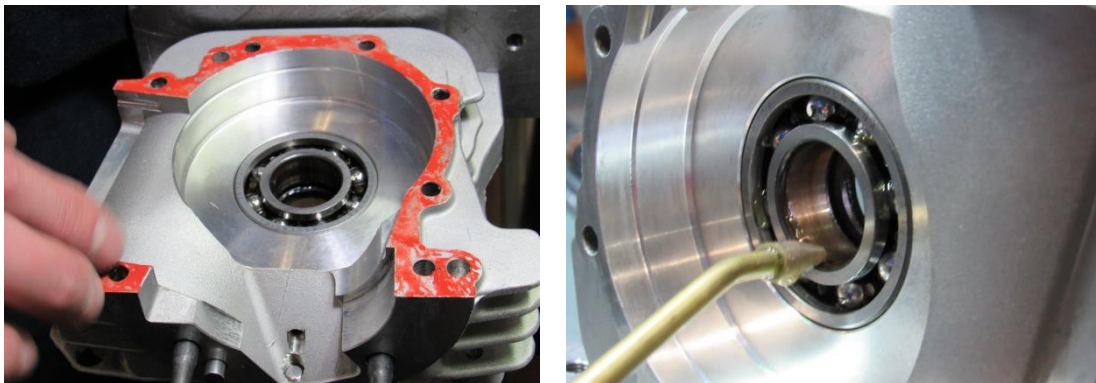

Reassembly crankcase. Fixing n°7 Screws (n°5 M6x45 n°3 M6x60), tighten with ALLEN WRENCH 5mm. Tighten with a torque of 10 Nm (90 lb-in).

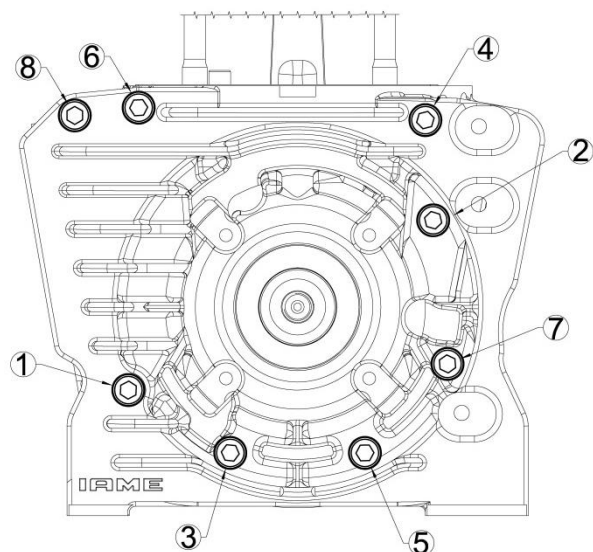
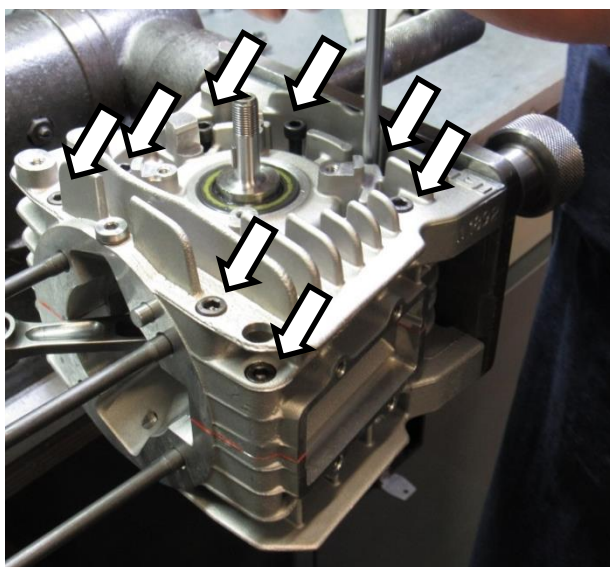

Where is necessary change the oil seal, apply special grease on lips before the insert (mark on seal to be outside), use special tool as in drawing S 725 / 1.

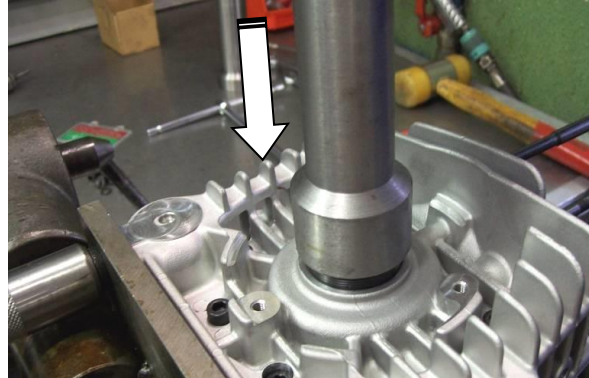

**ATTENTION:**  
**THE OIL SEAL SHOULD BE REPLACED AFTER MAX 10 HEURES AND ALWAYS WHEN DISASSEMBLED**

#### Install Piston

Check status of roller cage, the cage must be replaced after use of 160 litres or 20 hours.  
Check status of piston pin, must be replaced every replacing piston or 10÷20 hours.

**SEE ATTACHMENT ON MATCHING SELECTIONS**

**ATTENTION**  
**CHECK FIRST THE PISTON RING END GAP USING A THICKNESS GAUGE. MEASURE THE END GAP OF THE PISTON RING WHEN INSERTED IN THE CYLINDER GAP SHOULD BE 0.15÷0.40**  
**REPLACED THE PISTON RING IF THE END GAP EXCEEDS 0.50mm**

After install ring on the piston

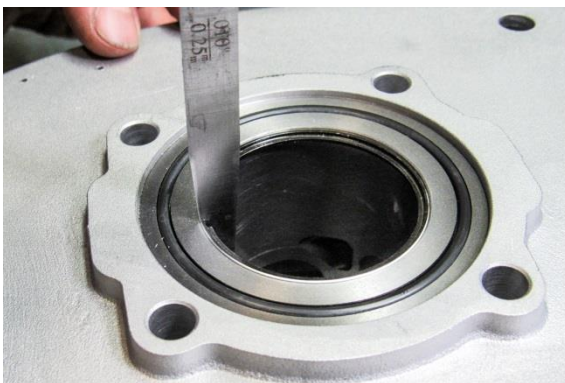

**ATTENTION**  
**CLEARANCE BETWEEN PISTON AND LINER MUST BE 0.090÷0.095mm, IF CLEARANCE IS HIGHER THAN 0.14mm THE PISTON MUST BE REPLACED (AN INSPECTION MUST BE CARRIED OUT AFTER ABOUT A USE OF 45 LITERS OR 5 HOURS OF USE, AND THE PISTONS ARE MEASURED AT 17.5mm FROM BOTTOM.**  
**ALWAYS REPLACE PISTON COMPLETE WITH THE RING.**



Match piston, pin, cage is the same as shown on the attachment, insert pin and cage on the piston. Lubricate any components. Make sure that the arrow on top of the piston is towards the exhaust. As general rule, the pin must be inserted in the hole with a little forced coupling. If coupling is slack, replaced it with a higher diameter pin. Using piston pin punch as guide.



### Position Circlip On Tool

Grease tool to keep circlip in place, use TOOL P.N. 10120, insert circlips and check that both the circlips are correctly in seat.

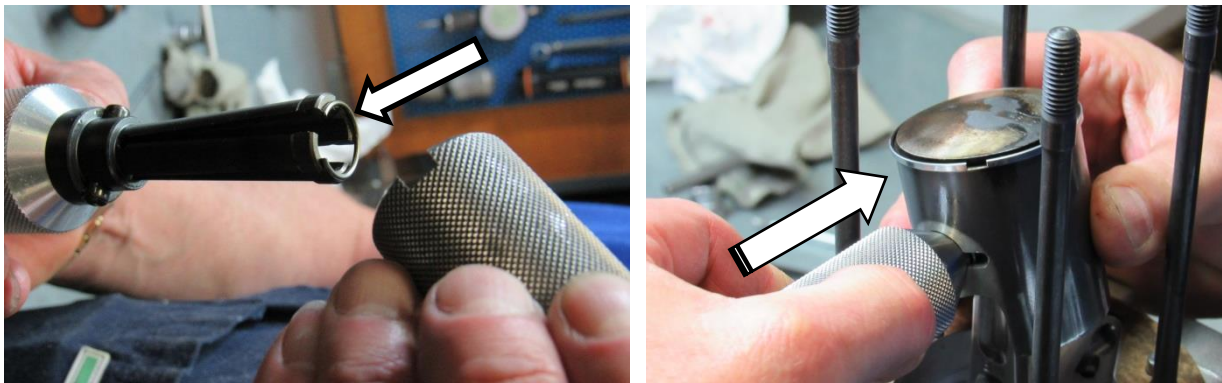

### Install a New Cylinder Gasket and Cylinder

Lubricate the cylinder and piston, install cylinder.



Check status of cylinder head, clean from deposits, do not scratch combustion chamber.

After the check, install O-Ring and cylinder head. Install n°4 head washer, then tighten n°2 Nuts M8 and n°2 Column nuts M8 with SOCKET WRENCH 13mm T-TYPE (18÷22Nm – 160÷190lb-in).

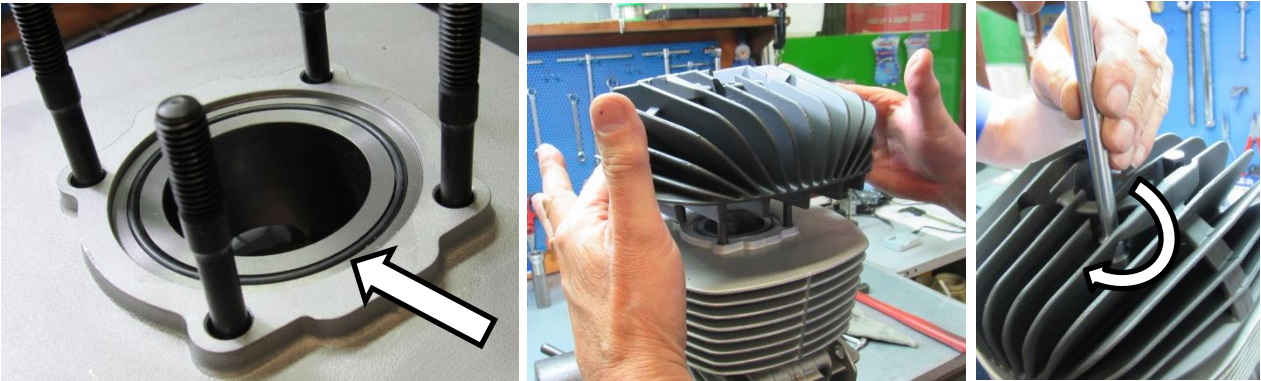

### Re-Assembly of The Clutch

Before assembling the clutch, wash with the diluent: the shaft cone, the starter wheel and the clutch drum.

Assemble the starter wheel on the clutch hub, tighten n°3 M6 TCEI with ALLEN WRENCH 5mm – T TYPE (10÷12 Nm – 90÷110 lb-in) and the dragging pin. Apply “Loctite” thread locker on screws.

**ATTENTION:**  
**IT'S NECESSARY TO ALWAYS INSTALL Ø7mm PIN, EVENTUAL KICKS COULD SHEAR THE SCREWS**



Apply “Loctite 641” for coaxial locking. Place the clutch hub and the starter wheel on the shaft. Insert on the crankshaft and position the ATT.037 STARTER WHEEL LOCKING TOOL.





Apply the "Loctite" thread locker. Assemble fixing nut, clutch hub and starter wheel, thought the STARTER WHEEL LOCKING TOOL and ALLEN WRENCH 27mm (torque 100÷110 Nm – 900÷990).

**WARNING: SCREW COUNTER CLOCKWISE AS THE NUT HAS LEFT-HAND THREAD.**

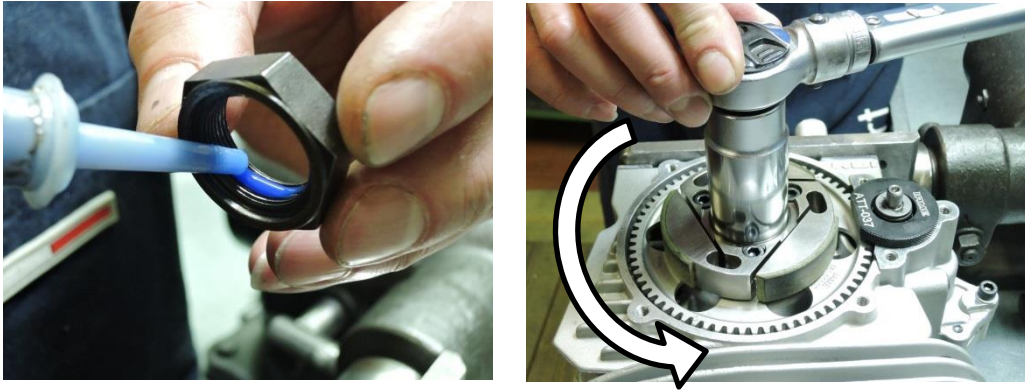

Assemble the internal washer (the bevel of the washer hole must be towards the shaft). Install the O-Ring. Clean the roller cage and grease it before assembling it on the shaft.



Mount the clutch drum and external washer (the bevel of the washer hole must be towards the shaft).

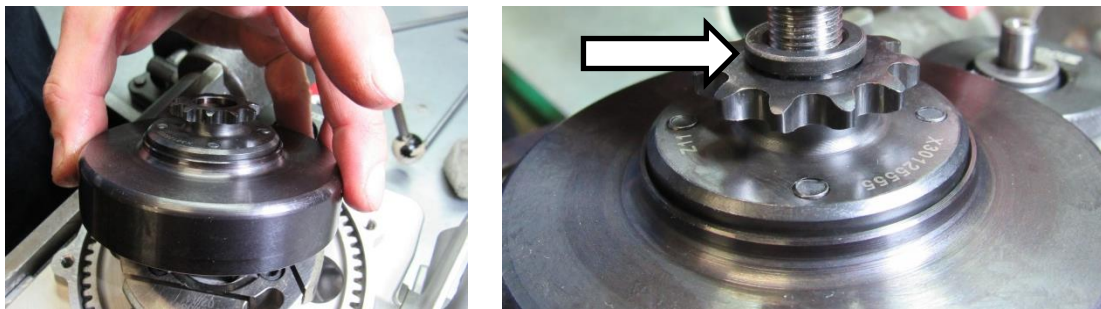

With the ATT.037 STARTER WHEEL LOCKING TOOL, tighten the drum retain nut (nut M10). Use RING WRENCH 17mm (torque at 30÷40 Nm – 270÷360 lb-in).

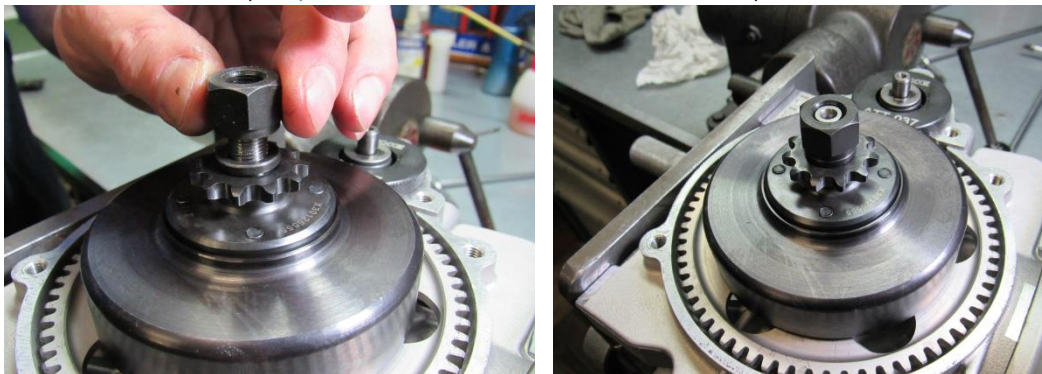

### Installation Bendix Support

Fixing n°4 Screw M6x45 use 5mm ALLEN WRENCH – T TYPE (torque at 8÷10 Nm – 70÷90 lb-in). Grease the Bendix cage, after insert the Bendix and fixing the cover, n°3 M6x25 with 5mm ALLEN WRENCH – T TYPE (torque at 6÷8 Nm – 55÷70 lb-in).

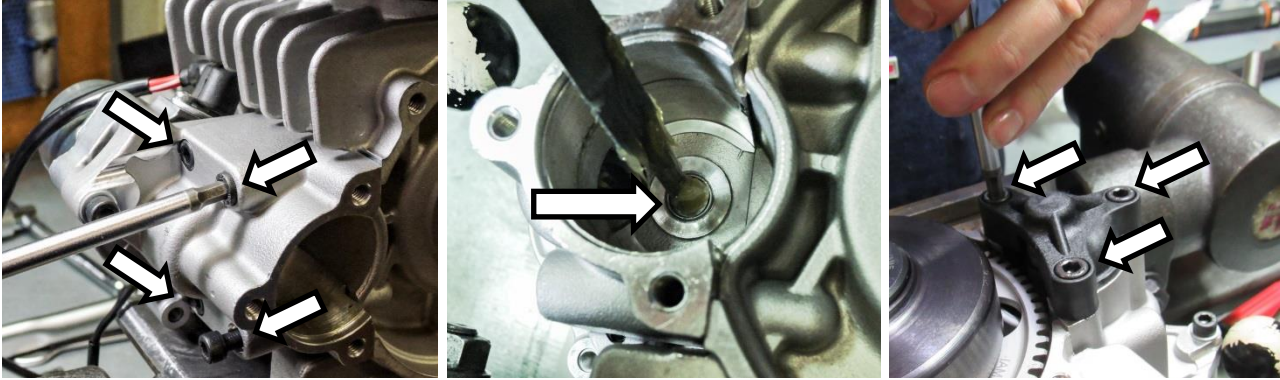

### Installation of the Starter Support

Place the support on the crankcase and tighten the n°3 M6x25 and n°1 M6x30, use 5mm ALLEN WRENCH – T TYPE (torque at 8÷10 Nm – 70÷90 lb-in).

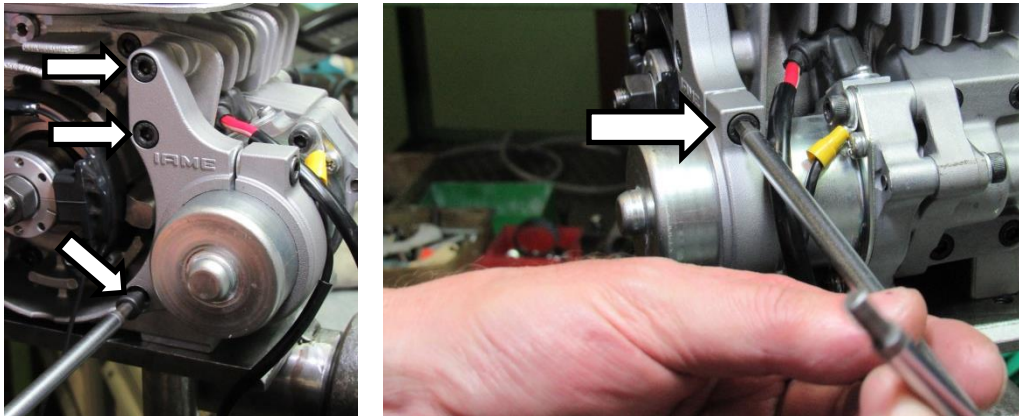

## Re-Assembly The Ignition

Install ignition rotor on shaft, the spacer-washer , the knurled washer and the nut M10. Remove the Bendix cover if was installed. Tighten all with a 12 POINT WRENCH 17mm and ATT.037 STARTER WHEEL LOCKING TOOL in position.

After remove ATT.037 STARTER WHEEL LOCKING TOOL, and install the Bendix cover.

Tighten n°3 M6x25 with 5mm ALLEN WRENCH – T TYPE (torque at 6÷8 Nm – 55÷70 lb-in).

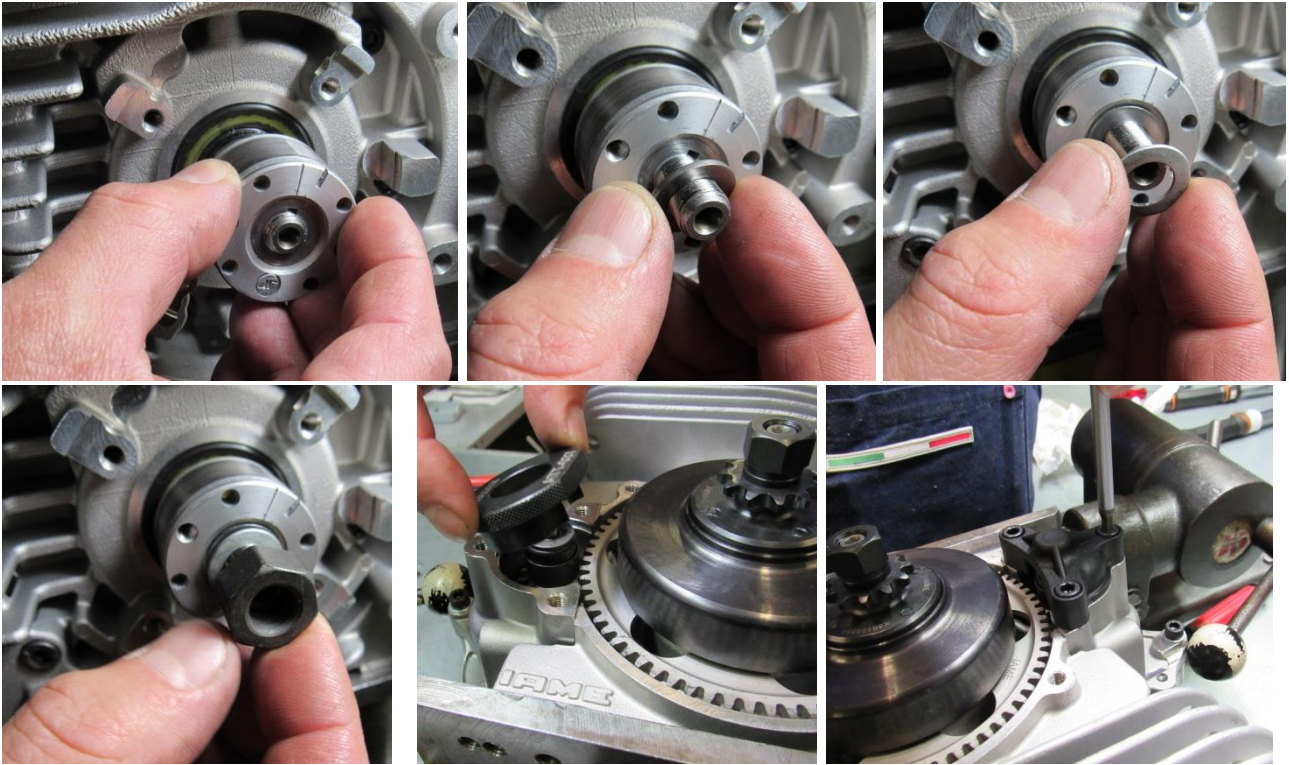

Install the stator ignition on the crankcase, position the washer and tighten but not in way definitely n°2 M5x25 screws and. Use 4mm ALLEN WRENCH – T TYPE.

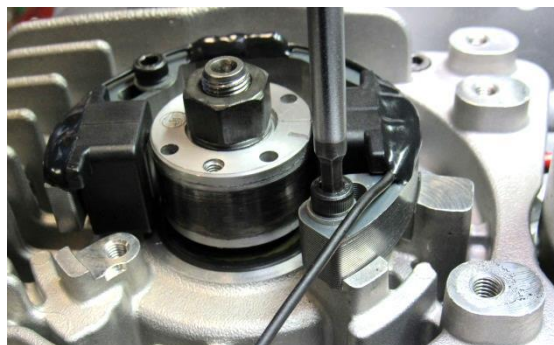

## Ignition Timing

Install dial gauge with adapter on head, rotate rotor until piston is at T.D.C. put dial gauge at zero. Looking at the ignition, turn rotor clockwise 2.1mm, fix rotor to avoid it from turning. Rotate the stator until the who marks (on rotor and stator) match. Fix stator with n°2 screw TCEI M5x25 with 4mm ALLEN WRENCH – T TYPE (torque at 5÷6 Nm – 45÷55 lb-in).

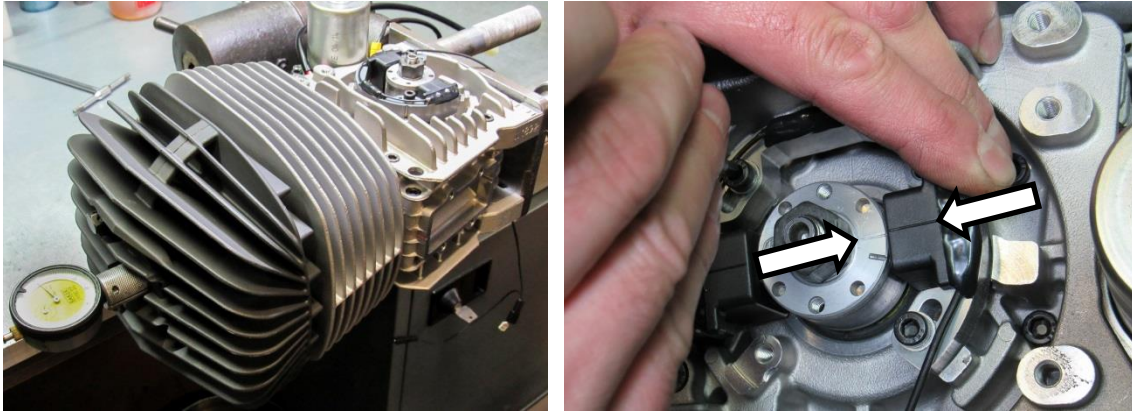

Ignition timing is completed.

## Install the Clutch Cover

Reassemble the clutch cover, tighten n°3 M6x30 with 5mm ALLEN WRENCH – T TYPE (torque at 8÷10 Nm – 70÷90 lb-in).

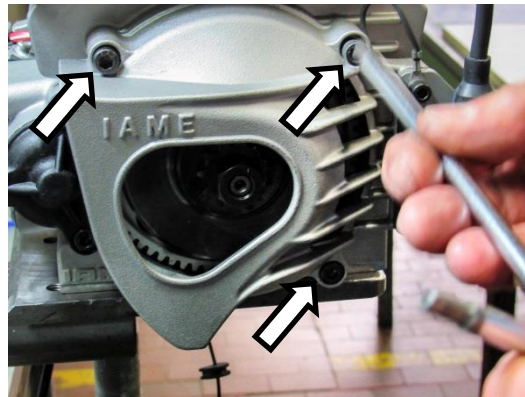

## Install the Spark-plug

Tighten with 20.8 HINGED PLUG BOX WRENCH – T TYPE (torque at 20÷26 Nm – 70÷90 lb-in).



## Install the Reed Pack

Place the inner gasket on inlet conveyor, check status.

### ATTENTION

FIRST CHECK STATUS OF REED PETALS BEFORE INSTALL THE REED PACK. REPLACE PETALS IF CRACKED, OR IF LOOKING WITH BACK LIGHT, THE PETALS DO NOT SHUT PERFECTLY, LOOSEN THE N°8 SCREWS AND INSERT NEW PETALS WITH BOTTOM CUT TOWARDS RIGHT.

Position the reed pack and itself gasket, install the reed pack group into the inlet seat of the engine, with IAME marking on top, check before tighten.

Tighten n°4 TCEI M6x25 with ALLEN WRENCH 5mm T TYPE. Place the carburettor gasket.

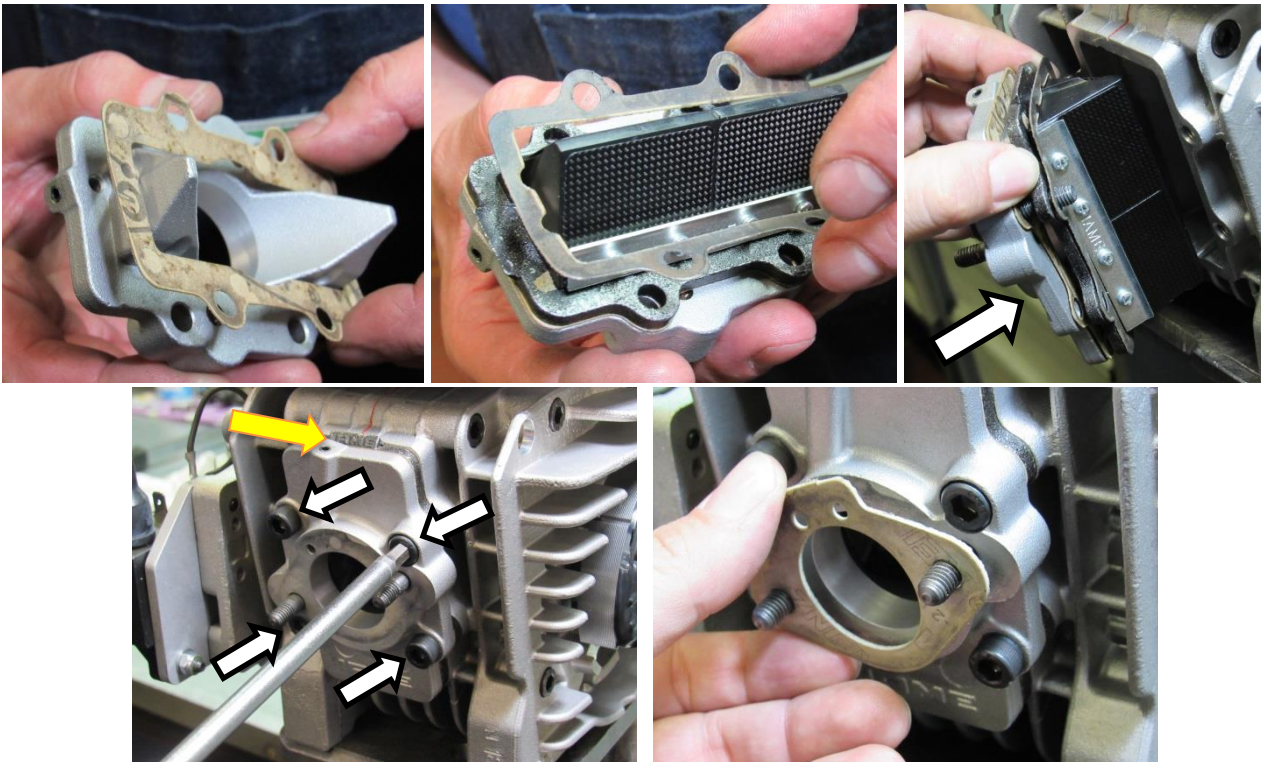

## Install the exhaust manifold

Place gasket and install the exhaust manifold. Insert washers and tighten n°2 COLUMN NUTS M8.

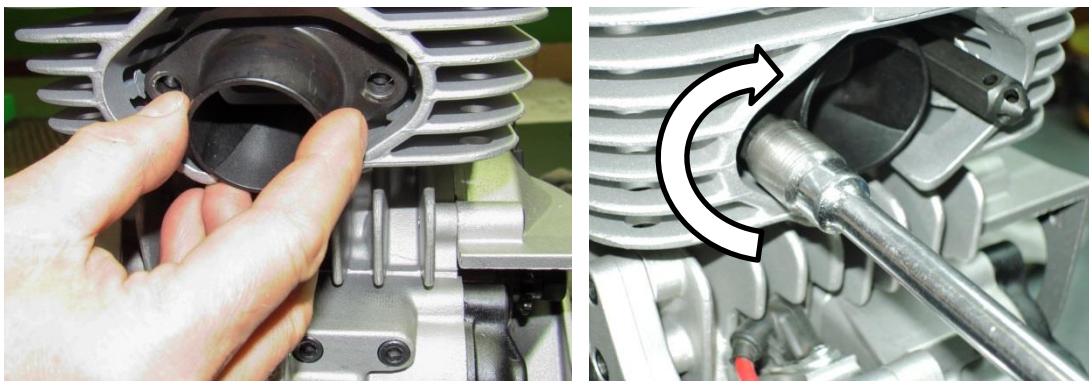

## FASTENER TORQUE VALUE

NOMINAL SIZE	Q.TY	FASTENER NAME	WRENCH	VALUES (Nm)	VALUES (in-lb)
M14x1,25	1	Spark Plug	Hex.20,8	20 ÷ 26	175 ÷ 230
M8x1,25	4	Head and Cylinder Nuts	Hex.13	18 ÷ 22	160 ÷ 190
M8x1,25	2	Exhaust manifold Stud Nuts	Hex.13	18 ÷ 22	160 ÷ 190
M6x1	4	Reed Group Screws	Allen 5	8 ÷ 10	70 ÷ 90
M5x0,8	3	Coil Attack Screws	Allen 4	5 ÷ 6	45 ÷ 50
M5x0,8	2	Ignition Stator Fixing Screws	Allen 4	5 ÷ 6	45 ÷ 50
M10x1	1	Ignition Rotor Fixing Nuts	Hex.17	20 ÷ 26	175 ÷ 230
M6x1	3	"Bendix" Support Cover Screws	Allen 5	6 ÷ 8	55 ÷ 70
M6x1	4	"Bendix" Support Screws	Allen 5	6 ÷ 8	55 ÷ 70
M6x1	4	Starter Support Fixing Screws	Allen 5	8 ÷ 10	70 ÷ 90
M6x1	3	Clutch Cover Fixing Screws	Allen 5	8 ÷ 10	70 ÷ 90
M10x1	1	Clutch Drum Fixing Nut	Hex.17	30 ÷ 40	260 ÷ 350
M20x1	1	Starter Ring Fixing Nut	Hex.30	100 ÷ 110	900 ÷ 990
M5x0,8	4	Engine Sprocket Fixing Screws	Allen 3	6 ÷ 8	55 ÷ 70
M6x1	3	Starter Ring Fixing Screws	Allen 5	10 ÷ 12	90 ÷ 110
M6x1	8	Crankcase Fixing Screws	Allen 5	8 ÷ 10	70 ÷ 90

## CROSS PATTERN LOCKING ORDER ON CRANKCASE

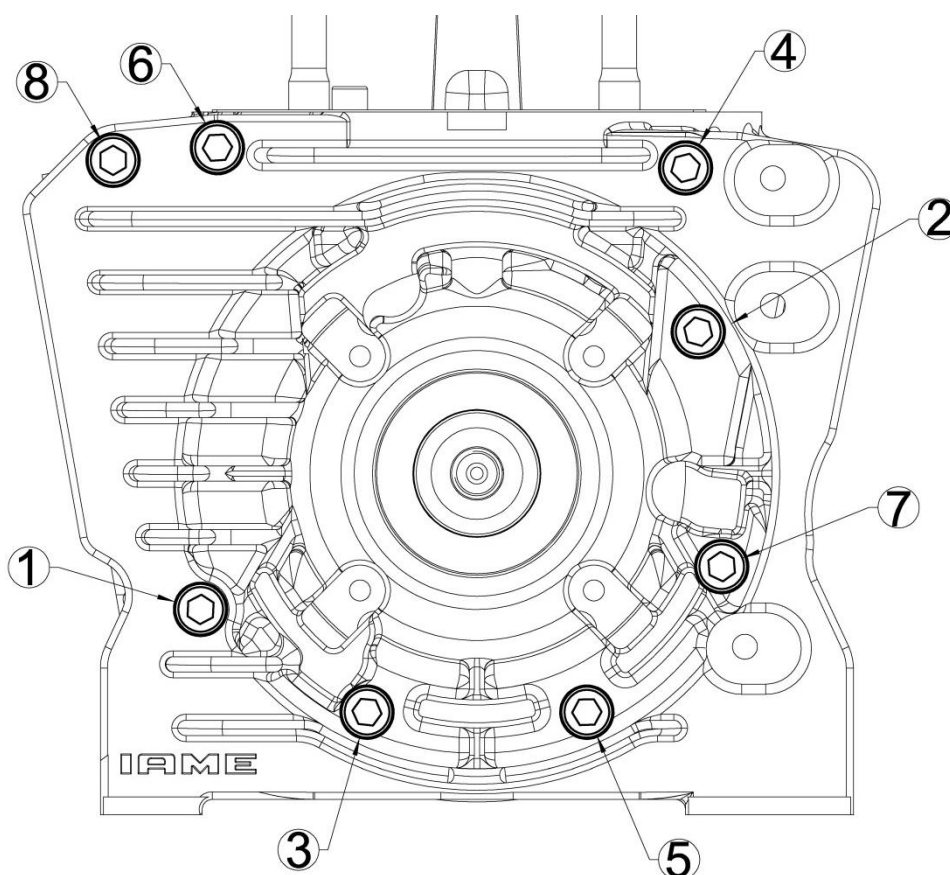

## MAIN PRESCRIPTIONS

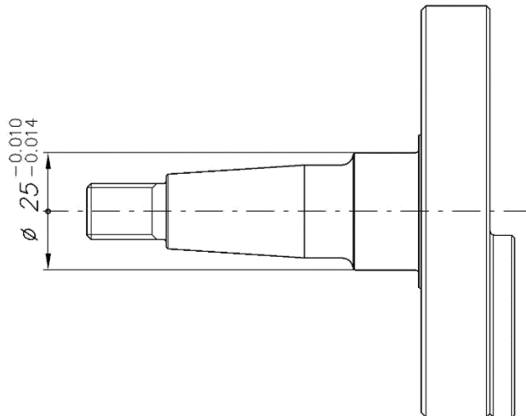
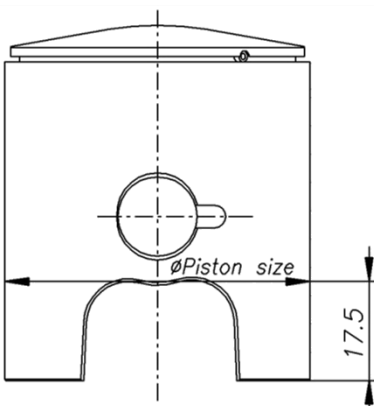
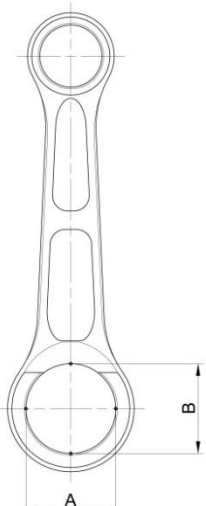
ENGINE CRANKSHAFT	MATCHING THE PISTON				
<div style="text-align: center;">  </div> <p><b>Bearing seat diameter on new engine</b></p> <p>Refer to the attached table to define the state of wear of the drive shafts.</p> <p>Replace when size is lower than 0.03mm vs. original.</p> <p><b>!</b> The <b>replacement operation</b> must be carried out after about a use of <b>60 hours</b>.</p>	<div style="text-align: center;">  </div> <p><b>!</b> <b>ATTENTION:</b> <u>Clearance between piston and liner must be: 0.090 / 0.095mm.</u></p> <p><u>If clearance is higher than 0.14mm, must be replaced the piston.</u></p> <p><b>!</b> An inspection must be carried out after about a use of 45 litres or 5 hours of use, and the pistons are measured at 17.5mm from bottom.</p> <p>The <b>replacement operation</b> must be carried out about a use of <b>10 hours</b> or 80 litres.</p> <p>Size of the liner to be matched with piston is marked on top of piston.</p> <p>Allowed ring gap 0.15 ÷ 0.40 mm.</p>				
MAX ALLOWED OVALIZATION ON CONROD					
<div style="text-align: center;">  </div> <p><b>Max. allowed ovalization between A and B on new conrod: 0.002mm</b></p> <p><b>Max. allowed ovalization between A and B on used conrod: 0.01mm</b></p> <p><b>!</b> An inspection must be carried out after about 30 hours use. When ovalization reaches 0,01mm (the difference between the measured diameter in the positions shown below "A" and "B") the conrod must be replaced.</p> <p>The <b>replacement operation</b> must be carried out about a use of <b>60 hours</b>.</p>	<div style="background-color: #92d050; text-align: center; padding: 5px; font-weight: bold;">ESTIMATED AVERAGE LIFE OTHER COMPONENTS</div> <table style="width: 100%; border-collapse: collapse;"> <tr> <td style="padding: 5px;">Big End Conrod Roller Bearing + Crankpin + silver washers</td> <td style="text-align: right; padding: 5px;">= 30 hours</td> </tr> <tr> <td style="padding: 5px;">Little End Conrod Roller Bearing + Piston Pin</td> <td style="text-align: right; padding: 5px;">= 10 to 20 hours</td> </tr> </table>	Big End Conrod Roller Bearing + Crankpin + silver washers	= 30 hours	Little End Conrod Roller Bearing + Piston Pin	= 10 to 20 hours
Big End Conrod Roller Bearing + Crankpin + silver washers	= 30 hours				
Little End Conrod Roller Bearing + Piston Pin	= 10 to 20 hours				



## WEAR STATUS EVALUATION CHART BEARINGS AND HALF CRANKSHAFT

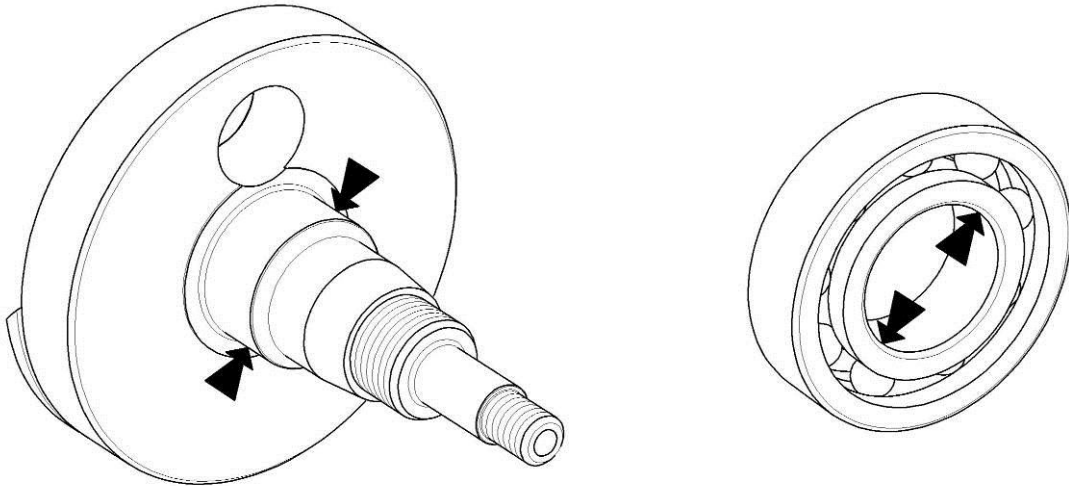

**NOTE:**

**ALWAYS CHECK DIMENSIONS IN DIFFERENT POINTS ON THE CIRCUMFERENCE, LOOKING FOR EVENTUAL OVALIZATIONS.**

The following chart shows the ovalization limits over which replacement is required

MEASURED PART (MEASURING INSTRUMENT)	LIMITS	Replace after Hours for Using
CRANKSHAFT – BEARING SEAT (MICROMETER 25 ÷ 50 1/100)	MIN. Ø24.96	60h
CRANKSHAFT BEARINGS (1/100 BORE GAUGE WITH CHECK RING Ø25)	* MAX. Ø25.03	30h

\*  **ATTENTION:**

**THE MEASURED VALUE ON THE BEARING MUST ALWAYS BE COMPARED WITH THE SEAT VALUE (ON SHAFT AND/OR BALANCE SHAFT), TO CHECK THAT PLAY BETWEEN SHAFT AND BEARING DOES NOT EXCEED THE LIMIT VALUE OF 0.05mm.**





LITTLE / BIG END CONROD BEARINGS CLEARANCE

**MATCHING PLAYS - CONROD LOWER END**

CONROD END	Ø CRANK PIN	ØROLLERS ON CAGE	PLAY	
			MIN.	MAX.
26 <sup>+0.024</sup> <sub>+0.020</sub>	20 <sup>-0.004</sup> <sub>-0.008</sub>	3 <sup>0</sup> <sub>-0.002</sub>	0.027	0.033

**MATCHING PLAYS - CONROD UPPER END**

CONROD END	Ø PISTON PIN		ØROLLERS ON CAGE	PLAY	
	RED	WHITE YELLOW		MIN.	MAX.
18 <sup>+0.016</sup> <sub>+0.012</sub>	14 <sup>+0.002</sup> <sub>0</sub>			0.010	0.020
		14 <sup>0</sup> <sub>-0.002</sub>	2 <sup>0</sup> <sub>-0.002</sub>	0.012	0.022
		14 <sup>-0.002</sup> <sub>-0.004</sub>		0.014	0.024



## OVERHAUL TOOL LIST

### SPECIFIC TOOLS AVAILABLE AT IAME

<u>DESCRIPTION</u>	<u>P.N.</u>
• PISTON STROKE LOCKER	10271
• SPROCKET PULLER	10612
• ROTOR PULLER	ATT.026
• PISTON PIN PUNCH	10200
• PISTON CIRCLIP ASSEMBLY TOOL	10120
• CRANKSHAFT ASSEMBLY KIT	10110-A
<i>it includes:</i>	
- <i>crankpin bush</i>	10150A
• KIT CRANKSHAFT DISASSEMBLY KIT	10100 – C2
<i>it includes:</i>	
- <i>Crankshaft plate</i>	10104A
- <i>Crankshaft support</i>	10100
- <i>Crankpin pusher</i>	10107
- <i>crankshaft insert</i>	10106
• TIMING CHECK TOOL	10192
• VOLUMETER	ATT.063 / 2

### SPECIFIC TOOLS – DRAWINGS ONLY – Draw. S725/1

<ul style="list-style-type: none"> <li>• ENGINE FIXING TOOL</li> <li>• BEARING DISASSEMBLY TOOL</li> <li>• BEARING ASSEMBLY TOOL</li> <li>• CIRCLIP ASSEMBLY TOOL</li> </ul>
--

<u>STANDARD TOOLS</u>	
• ALLEN WRENCH T TYPE	4mm
• ALLEN WRENCH T TYPE	5mm
• SOCKET WRENCH T TYPE	10mm
• SOCKET WRENCH T TYPE	13mm
• 12 POINT WRENCH	13mm
• 12 POINT WRENCH	17mm
• 12 POINT WRENCH	27mm
• HINGED PLUG BOX WRENCH – T TYPE	20.8mm
• SCREWDRIVER WITH ROUNDED EDGES	
• PLASTIC MALLET	
• SOCKET TYPE-DYNAMOMETRIC	13mm / 10mm
• 5 MeT PRESS	



# FIXING TOOL ON BENCH VISE

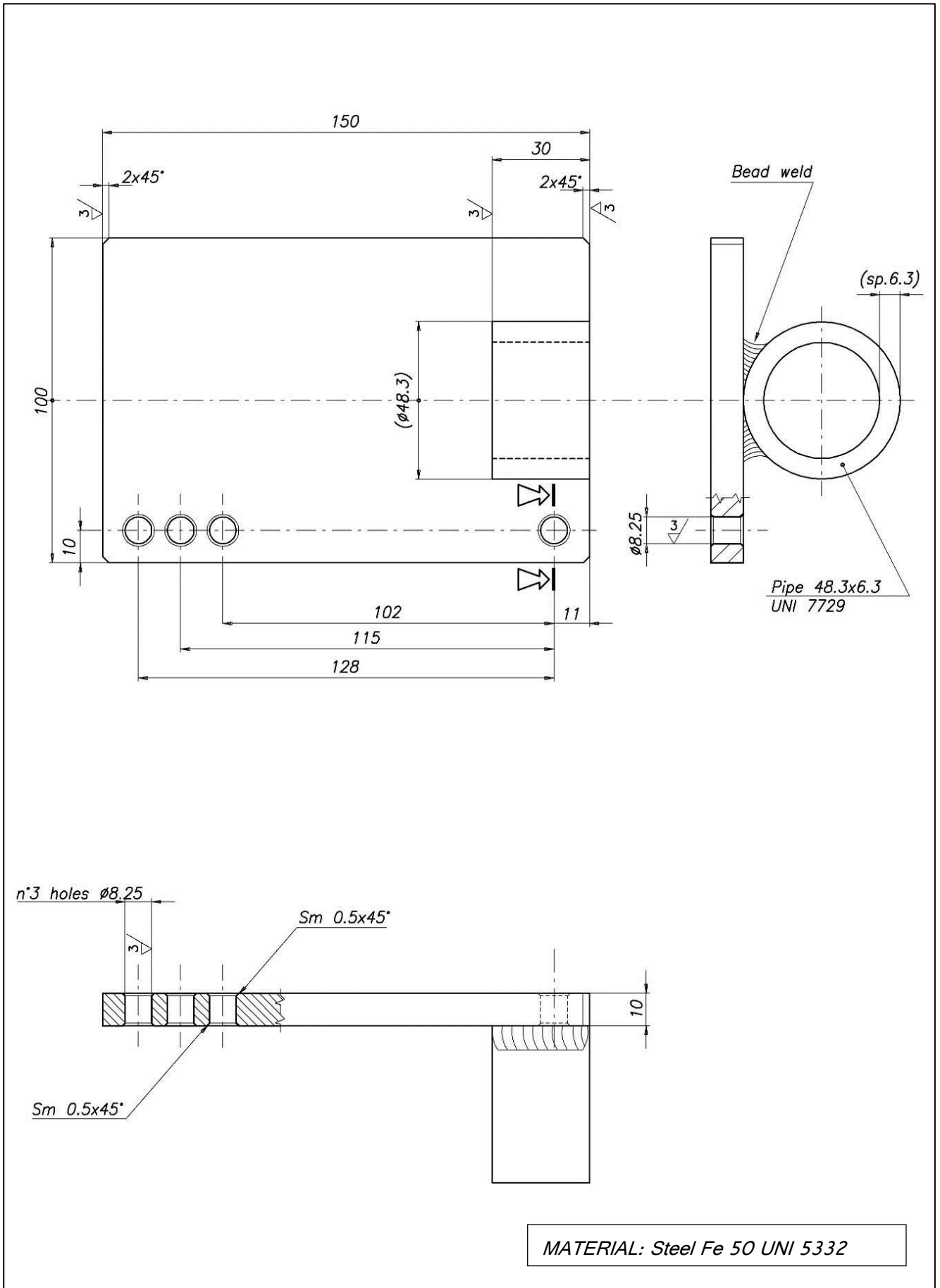

# Drawing S725/1

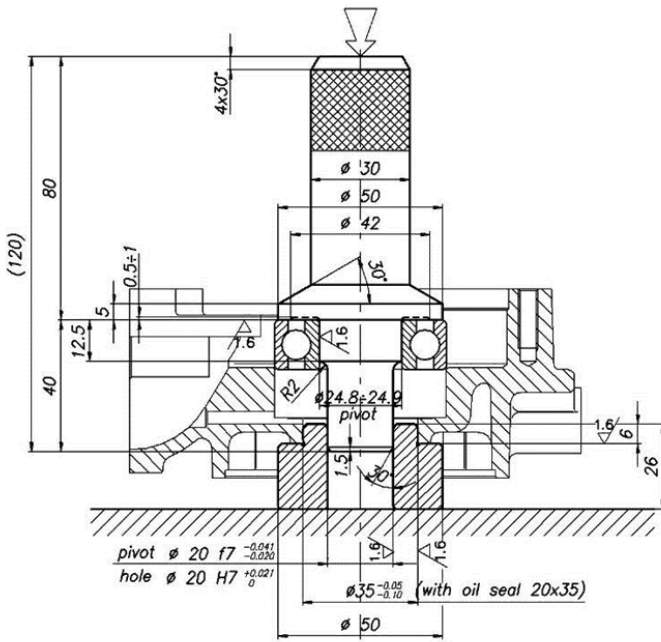

BEARING ASSEMBLY TOOL (Steel C16 cmt. tmp.)

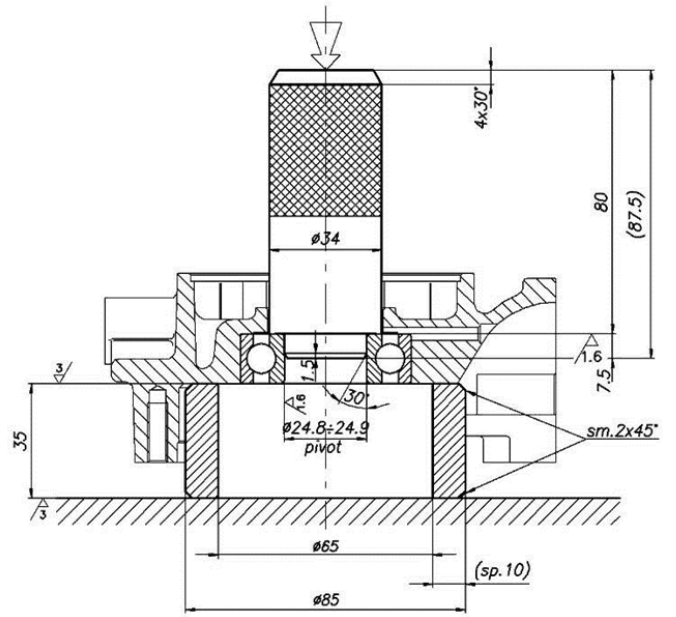

BEARING DISASSEMBLY TOOL (Steel C16 cmt. tmp.)

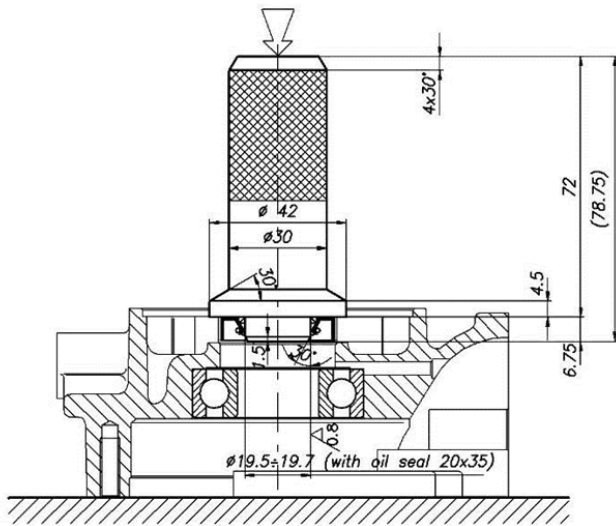

OIL SEAL ASSEMBLY TOOL WITH (Steel C16 UNI 5331)  
DISASSEMBLED CRANKSHAFT

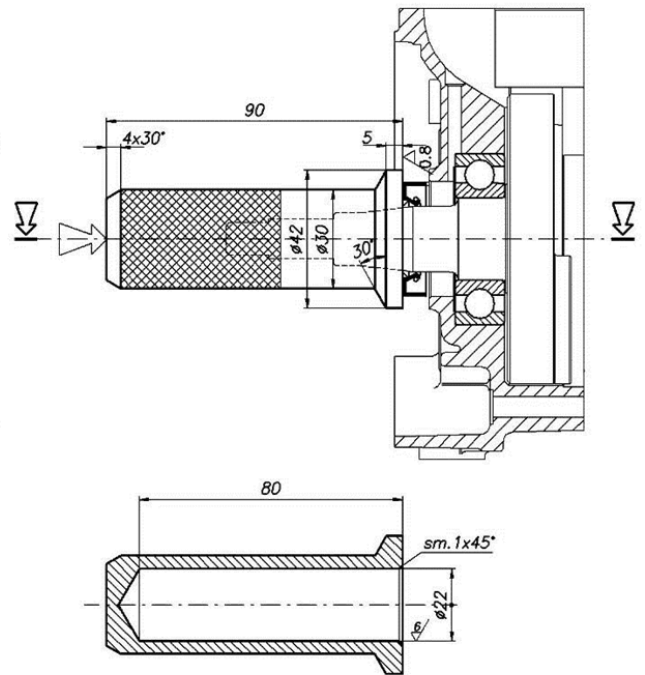

OIL SEAL ASSEMBLY TOOL WITH (Steel C16 UNI 5331)  
INSTALLED CRANKSHAFT



# WIRING DIAGRAM

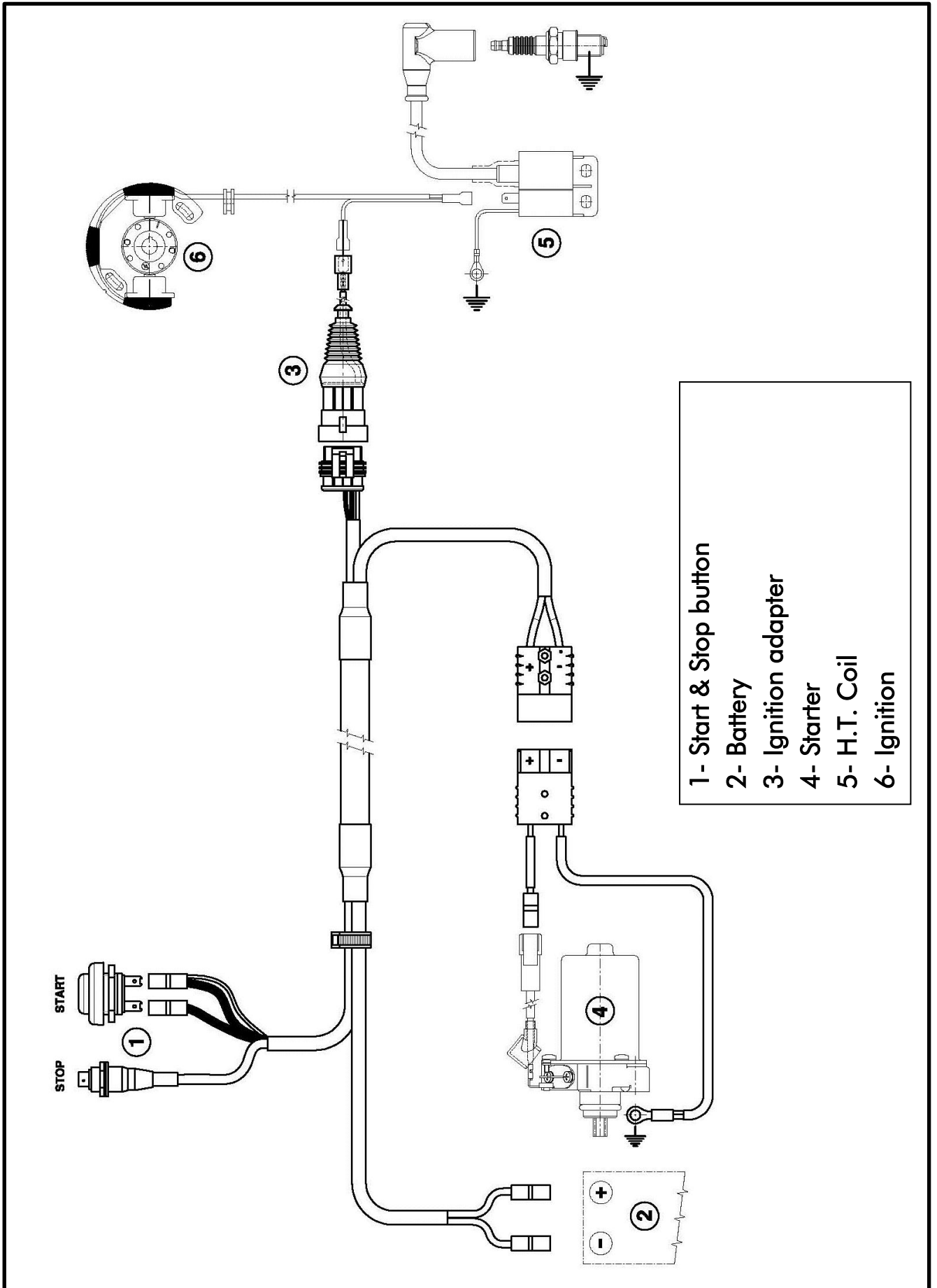

- 1- Start & Stop button
- 2- Battery
- 3- Ignition adapter
- 4- Starter
- 5- H.T. Coil
- 6- Ignition

